

HONDA

CR250R ELSINORE



OWNER'S

MANUAL

IMPORTANT NOTICE

THIS VEHICLE IS DESIGNED AND MANUFACTURED FOR COMPETITION USE ONLY AND IS SOLD "AS IS" WITH NO WARRANTY. IT DOES NOT CONFORM TO FEDERAL MOTOR VEHICLE SAFETY STANDARDS AND OPERATION ON PUBLIC STREETS, ROADS, OR HIGHWAYS IS ILLEGAL.

STATE LAWS PROHIBIT OPERATION OF THIS VEHICLE EXCEPT IN AN ORGANIZED RACING OR COMPETITIVE EVENT UPON A CLOSED COURSE WHICH IS CONDUCTED UNDER THE AUSPICES OF A RECOGNIZED SANCTIONING BODY OR BY PERMIT ISSUED BY THE LOCAL GOVERNMENTAL AUTHORITY HAVING JURISDICTION.

A U.S.D.A. APPROVED SPARK ARRESTER/MUFFLER IS AVAILABLE AT AUTHORIZED HONDA DEALERS. INSTALLATION BY RECOMMENDED FACTORY PROCEDURES REDUCES THE NOISE LEVEL (93 DBA.) PERFORMANCE WILL BE DECREASED AND RETURNING IS NECESSARY. IN SOME STATES THIS VEHICLE, EVEN WHEN EQUIPPED WITH THE SPARK ARRESTER/MUFFLER, MAY NOT COMPLY WITH OFF-ROAD LAWS AND REGULATIONS. FIRST DETERMINE THAT OPERATION IN OTHER THAN SANCTIONED RACING EVENTS IS LEGAL.

OPERATOR ONLY. NO PASSENGERS.

This motorcycle is designed and constructed as an operator only model. The vehicle load limit and seating configuration do not safely permit the carrying of a passenger.

READ OWNER'S MANUAL CAREFULLY.

All information, illustrations directions and specifications included in this publication are based on the latest product information available at the time of approval for printing.

HONDA MOTOR CO., LTD. reserves the right to make changes at any time without notice and without incurring any obligation whatever.

No part of this publication may be reproduced without written permission.

TO THE NEW OWNER

By selecting a Honda motocross "CR250R ELSINORE" as your new motorcycle, you have placed yourself in a distinguished family of motorcycle owners and riders.

The CR250R ELSINORE is designed and built by Honda engineers who spent as much time riding as at the drawing board, and it offers outstanding features.

WARNING

The CR250R is a high performance racing motorcycle utilizing the latest motocross technology. This motorcycle is intended for competition use by experienced riders only.

The purpose of this manual is to acquaint you with the operation and maintenance of your new Honda CR250R ELSINORE.

Please take the time to read this manual carefully. Proper care and maintenance are essential for trouble-free operation and optimum performance.

Your authorized Honda dealer will be glad to provide further information and is fully equipped to handle your service needs.

IMPORTANT SAFETY NOTICE

WARNING

Indicates a possibility of personal injury or loss of life if instructions are not followed.

CAUTION

Indicates a possibility of equipment damage if instructions are not followed.

Detailed descriptions of standard workshop procedures, safety principles and service operations are not included. It is important to note that this manual contains *some* warnings and cautions against some specific service methods which could cause **PERSONAL INJURY** to service personnel or could damage a vehicle or render it unsafe. Please understand that those warnings could not cover all conceivable ways in which service, whether or not recommended by Honda might be done or of the possible hazardous consequences of each conceivable way, nor could Honda investigate all such ways. Anyone using service procedures or tools, whether or not recommended by Honda *must satisfy himself thoroughly* that neither personal safety nor vehicle safety will be jeopardized by the service method or tools selected.

© 1978 HONDA MOTOR CO., LTD
SERVICE DIVISION

CONTENTS

I. OPERATING INSTRUCTIONS

1. Controls.....	1
2. Fuel.....	2
3. Riding the Motorcycle.....	3
• Starting the engine.....	3
• Stopping the engine.....	3
• Braking the motorcycle.....	3
• Breaking-in the motorcycle.....	4

II. INSPECTION AND MAINTENANCE

1. Service Precautions.....	5
2. Parts Replacement.....	6
3. Inspection Check List.....	7
4. Maintenance Procedures.....	8
• Transmission oil.....	8
• Spark plug.....	9
• Clutch.....	10
• Ignition check.....	11
• C.D.I unit.....	11
• Cylinder head, cylinder.....	11
• Piston, piston ring.....	11
• Air cleaner.....	12
• Handlebars.....	13
• Throttle grip.....	13
• Front and rear wheels.....	13
• Front fork.....	14
• Rear suspension.....	15
• Front brake.....	15
• Rear brake.....	16
• Drive chain maintenance.....	17
• Drive chain tension roller, guide roller.....	19
• Chain protector.....	19
• Chain slider.....	19
• Fuel tank.....	20
• Fuel filter.....	20
• Expansion chamber.....	20

III. SERVICING THE ENGINE

1. Service Not Requiring Engine Removal.....	21
2. Engine Removal and Installation.....	21
3. Cylinder Head, Cylinder and Piston.....	24
4. Clutch.....	28
5. Kick Starter.....	31
6. Gearshift Mechanism.....	32
7. Crankcase and Transmission.....	35
8. Crankshaft and Connecting Rod.....	38
9. Carburetor.....	39
10. Air cleaner.....	43

IV. SERVICING THE FRAME

1. Handlebar and Front Suspension.....	44
2. Rear Suspension.....	48
3. Front Wheel and Front Brake.....	51
4. Rear Wheel and Rear Brake.....	54

V. SERVICING THE ELECTRICAL SYSTEM.....

• Wire and Cable Routing.....	57
-------------------------------	----

VI. OPTIONAL PARTS

1. Optional Parts, List.....	59
2. Spark Arrester/Muffler Installation.....	60
3. Carburetor Setting.....	61
4. Cylinder.....	62

VII. SERVICE DATA

1. Troubleshooting.....	63
2. Torque Specifications.....	66
3. Service Data.....	67
4. Wiring Diagram.....	68
5. Special Tools.....	69
6. Specifications.....	70

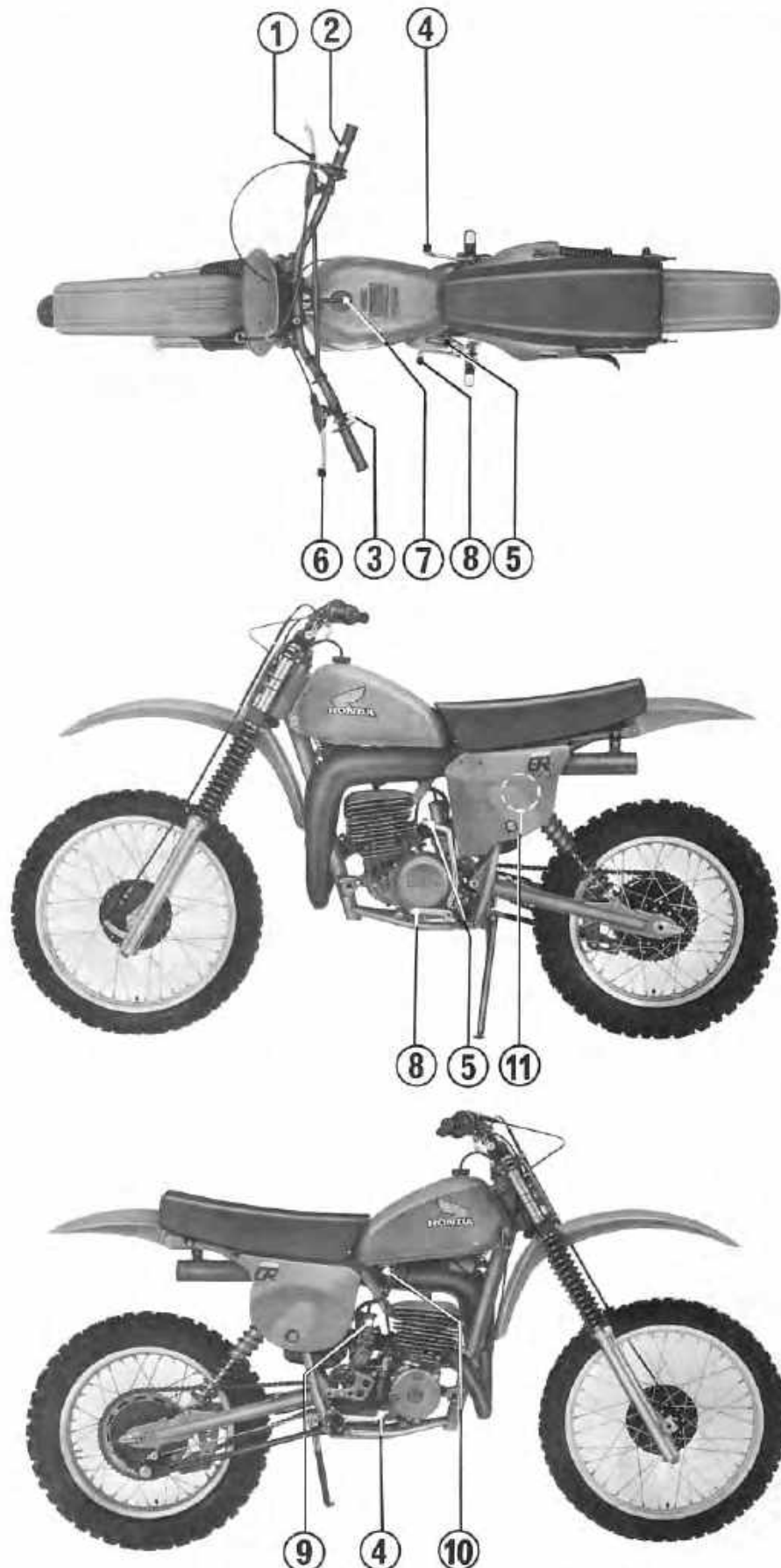

1. CONTROLS

- (1) Front brake lever
- (2) Throttle grip
- (3) Engine stop switch
When shutting off engine, press in the engine stop switch button.
- (4) Rear brake pedal
- (5) Kickstarter pedal
- (6) Clutch lever
- (7) Fuel tank filler cap
- (8) Gear change pedal
The transmission has 5 speeds. Depress the pedal to shift into 1st gear. Raise the pedal to shift into 2nd, 3rd, 4th and 5th. Neutral is located between 1st and 2nd.
- (9) Fuel mixture enrichment knob
When starting a cold engine, raise the fuel mixture knob and fully depress the kickstarter pedal.
- (10) Fuel valve
When the fuel valve is turned to "OFF", fuel cannot flow from the fuel tank to the carburetor. When the fuel valve is turned to "ON", fuel will flow from the tank to the carburetor.
- (11) Rear shock absorber adjuster
The rear shock absorber springs have three settings for precise adjustment of the rear suspension to suit riding conditions and differences in rider weight.

Fig. 1-1

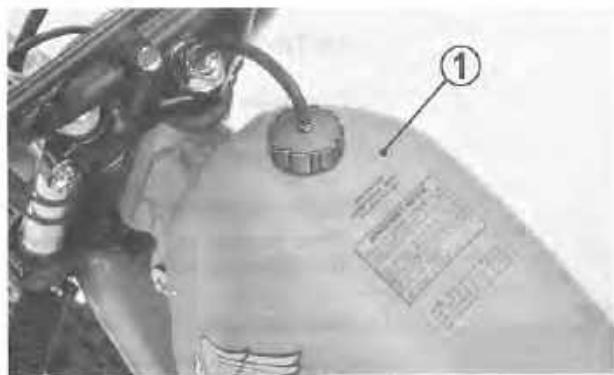

Fig. 1-2 (1) Fuel tank

2. FUEL

The Honda CR250R ELSINORE has a two-stroke engine that requires a gasoline-oil mixture.

The capacity of the fuel tank is 8.5ℓ (2.2 US gal. 1.9 Imp. gal.).

- Any automotive gasoline with a pump octane number $\left(\frac{R+M}{2}\right)$ of 86 or higher, or research octane number of 91 or higher may be used.
If "knocking" or "pinging" occurs, try a different brand of gasoline or a higher octane grade.

USE HONDA 2-STROKE INJECTOR OIL OR EQUIVALENT.

- Premix gasoline and oil in a ratio of 20:1. Prepare the fuel mixture in a clean container, and shake until thoroughly mixed before filling the fuel tank.

CAUTION

Too much oil will cause excessive smoking and spark plug fouling. Too little oil will cause engine damage or premature wear. Mix fuel in a ratio of 20 parts gasoline to 1 part oil.

- Vegetable oils separate from gasoline more easily than mineral oils, especially in cold weather. It is advisable to use mineral oil when ambient temperatures of below 0°C (32°F) are expected.
- If the gasoline-oil mixture is left standing in a container for a long period of time, lubricity will deteriorate. Use the mixture within 24 hours.
- Once an oil container is opened, the oil must be used within one month, since oxidation may occur.

CAUTION

Do not mix vegetable and mineral oils.

WARNING

Gasoline is flammable and explosive under certain conditions. Always stop the engine and do not smoke or allow open flames or sparks near the motorcycle when refueling.



3. RIDING THE MOTORCYCLE

Starting The Engine

Check the transmission oil level before starting engine (page 8).

Cold engine starting

1. Turn the fuel valve to "ON".
2. Shift the transmission into neutral.
3. Raise the fuel mixture enrichment knob.
4. With closed throttle, operate the kickstarter pedal several times with rapid and full strokes.
5. Open the throttle slightly ($1/8 - 1/4$) and again operate the kickstarter pedal.
6. After the engine starts, run it for a few minutes, "blipping" the throttle, until it warms up enough to idle with fuel mixture enrichment knob lowered. The knob should be lowered as soon as possible to prevent spark plug fouling.

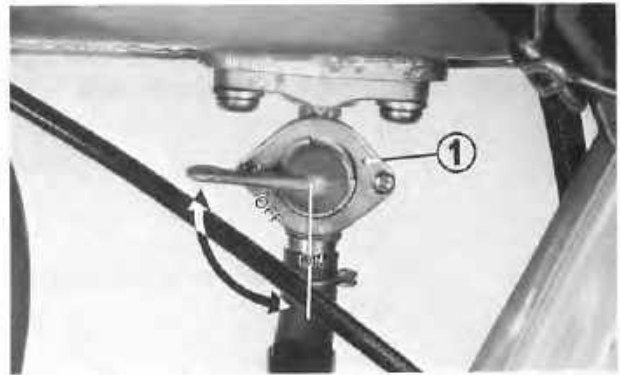

Fig. 1-3 (1) Fuel valve



Fig. 1-4 (1) Fuel mixture enrichment knob

Warm engine starting

1. Follow the cold engine starting procedure without operating the fuel mixture enrichment knob.

WARNING

Exhaust contains poisonous carbon monoxide gas.
Never run the engine in a closed garage or in a confined area.

Stopping The Engine

1. Shift the transmission into neutral.
2. Turn the fuel valve "OFF".
3. Lightly snap the throttle grip 2-3 times, and then close the throttle grip.
4. When the engine slows down, depress the engine stop switch until the engine stops completely.

NOTE:

Failure to close the fuel valve may cause the carburetor to overflow, filling the crankcase with fuel and resulting in hard starting.

Braking the motorcycle

For maximum deceleration, close the throttle and apply both front and rear brakes equally. Disengage the clutch as the motorcycle comes to a stop. Independent use of the front or rear brake may be advantageous under certain conditions. Downshift progressively as speed is reduced to ensure good acceleration when speed is resumed.

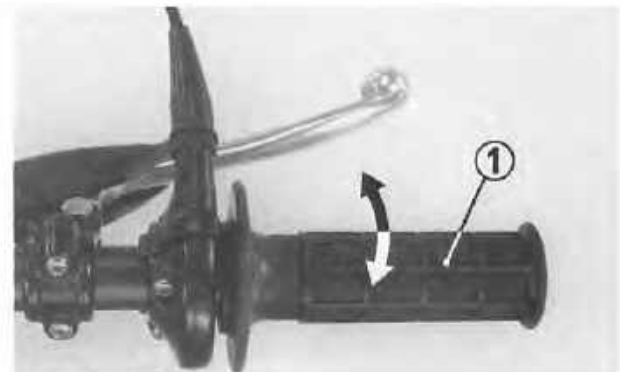

Fig. 1-5 (1) Throttle grip

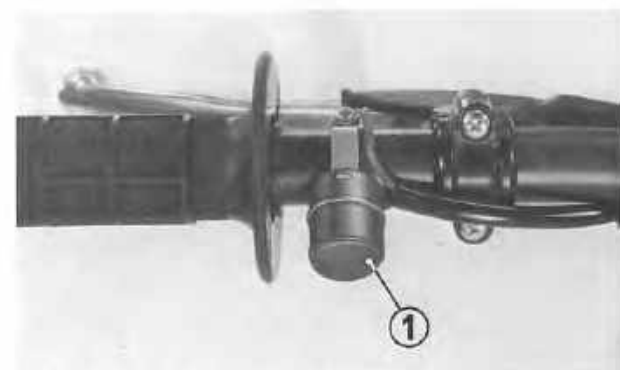

Fig. 1-6 (1) Engine stop switch

Breaking-In The Motorcycle**New motorcycle:**

When first riding a new motorcycle, operate the motorcycle for the first hour (about 25 km/16 miles) using not more than half throttle and shifting gears so that the engine does not lug.

CAUTION

To replenish the fuel tank, be sure to use pre-mixed gasoline-oil mixture.

Reconditioned motorcycle:

- ◆ After replacing the cylinder and crankshaft, operate the motorcycle for the first hour observing the same caution as in new motorcycle.
- ◆ When the piston, piston rings, gears, etc. are replaced, they must be broken in by operating the motorcycle for the first 30 minutes using not more than half throttle and shifting gears so that the engine does not lug.

CAUTION

Revvng the engine more than necessary may cause engine damage.

1. SERVICE PRECAUTIONS

- Always install new gaskets, O-rings, cotter pins, piston pin clips, circlips, etc. when reassembling.
- When tightening bolts, nuts or screws, start with the larger diameter or inner fasteners, and tighten them to the specified torque using a criss-cross pattern.
- Use genuine HONDA parts or their equivalent when servicing or replacing.
- Be sure to use special tools where specified.
- Clean the engine before disassembly.
- Clean parts in cleaning solvent when disassembling. Lubricate any sliding surface before reassembling.
- After reassembling, check all parts for proper installation and operation.
- Grease parts by coating or filling where specified.

WARNING

Gasoline or low flash point solvents are highly flammable or explosive and must never be used for cleaning parts or the air filter element. Fire or explosion could result.

NOTE:

All service data is listed at the end of this manual.

Grease Points:

1. Steering stem bearings, top and bottom seals
2. Front/rear wheel hub bearings, dust seals
3. Swing arm pivot bearings, dust seal, collar
4. Rear brake stopper arm bushing
5. Rear brake panel bushing
6. Drive chain guide roller bearing
7. Drive chain tensioner roller bearing
8. Front/rear brake cams
9. Side stand pivot bolt
10. Brake pedal pivot
11. Kickstarter joint



Fig. 2-1

2. REPLACEMENT PARTS

Parts Requiring Periodic Replacement

Item	Replacement Interval	Cause	Service Limit
Engine			
Piston	Every 310 miles (500km) (5 races)	Damage or wear at skirt	1,250 miles (2,000 km)
Piston ring	Every 310 miles (500km) (5 races)	Damage at ends or wear	1,250 miles (2,000km)
Piston pin	Every 620 miles (1,000km) (10 races)	Burning, damage or wear	1,250 miles (2,000km)
Connecting rod small end bearing	Every 620 miles (1,000km) (10 races)	Burning, damage or wear	1,250 miles (2,000km)
Spark plug	Every 310 miles (500km) (5 races)	Worn electrode or damaged insulator	620 miles (1,000km)
Drive sprocket	Every 620 miles (1,000km) (10 races)	Wear or damage	940 miles (1,500km)
Fixing plate	Every 620 miles (1,000km) (10 races)	Wear or damage	940 miles (1,500km)
Transmission oil	First 60 miles (100km); thereafter, every 620 miles (1,000km)	Contamination or emulsion	
Frame			
Drive chain	Every 190 miles (300km) (3 races)	Elongation or wear	310 miles (500km)
Drive sprocket	Every 190 miles (300km) (3 races)	Wear or damage	250 miles (400km)
Chain tensioner roller	Every 310 miles (500 km)	Wear	O.D.: 25 mm (0.9 in.)
Chain guide roller	Every 620 miles (1,000km)	Wear	O.D.: 25 mm (0.9 in.)
Chain slider	Every 620 miles (1,000km)	Wear	
Cables	Every 380 miles (600km)	Damage	
Front fork oil	First 60 miles (100km); thereafter, every 120 miles (200km)		620 miles (1,000km)

Fast Wearing/Consumable Parts

Item	Cause	Service Limit
Engine		
Cylinder head gasket	Compression leak	
Reed valve	Damage or fatigue	1,250 miles (2,000km)
Clutch disc	Wear or discoloration	1,250 miles (2,000km)
Cylinder gasket	Whenever disassembled	
Left crankcase cover gasket	Damage	
Frame		
Front/rear tire	Wear (tread depth: 8m/5/16 in.)	
Rear brake stopper arm		
Rear brake panel bushing		
Chain guide plate	Wear or damage	
Side cover	Damage	
Front number plate	Damage	
Front/rear fender	Damage	
Clutch lever/holder	Play or damage	
Brake lever/holder	Play or damage	
Handlebar	Bend or cracks	
Throttle housing	Damage	
Grip rubber		
Gearshift pedal	Damage	
Brake pedal	Damage	
Chain adjuster/bolt	Damage or bend	
Air cleaner element	Damage	
Exhaust chamber spring/hook	Fatigue or damage	

3. INSPECTION CHECK LIST

Prepractice Inspection

Ref. page

- Transmission oil for proper level 8
- Spark plug and high tension lead terminal for looseness 9
- Clutch for proper operation 10
- Carburetor throttle valve for proper operation 13
- Steering head and related parts for condition 13
- Spokes for looseness 13
- Tires for correct inflation pressure and damage 13
- Rim locks for looseness 13
- Brakes for correct free play and operation 15
- Drive chain for correct tension and adequate lubrication 17
- Every possible part for looseness (especially, cylinder head nuts, engine mounting bolts, axle nuts, drive chain adjusters, drive chain guide, wire harness connectors, etc.) -
- Drive chain guide and tensioner rollers for damage or wear 19
- Drive chain guide rollers and tensioner rollers for adequate lubrication 19
- Expansion chamber spring for damage or tension 20

Prerace Inspection

Ref. page

- All items "Prepractice inspection" -
- Spark plug for heat range and carbon fouling 9
- Clutch friction discs for wear 10
- Cylinder head and piston for carbon buildup 11
- Air cleaner element for contamination 12
- Cables for proper lubrication and condition 13
- Brake shoes for wear and contact 15
- Drive and driven sprockets for wear 17
- Fuel system for contamination 19
- Expansion chamber for cracks or damage 20

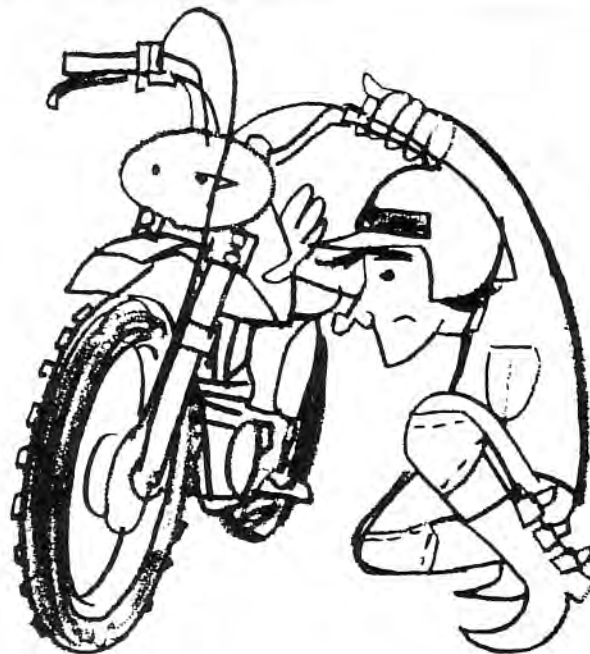

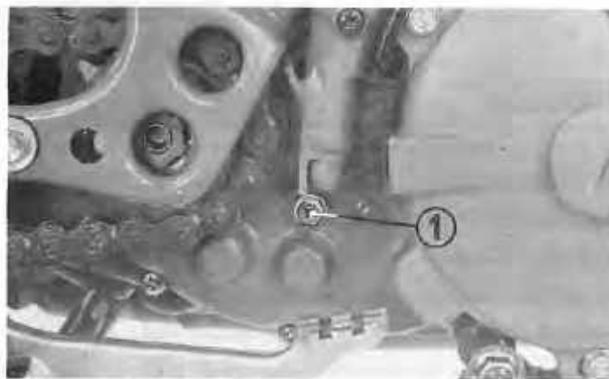

Fig. 2-2 (1) Oil check bolt

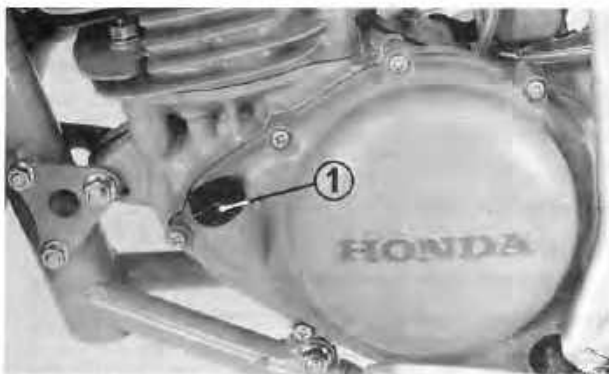

Fig. 2-3 (1) Oil filler cap



Fig. 2-4 (1) Drain plug

Recommended oil viscosity:
General, all temperatures
SAE 10W-40

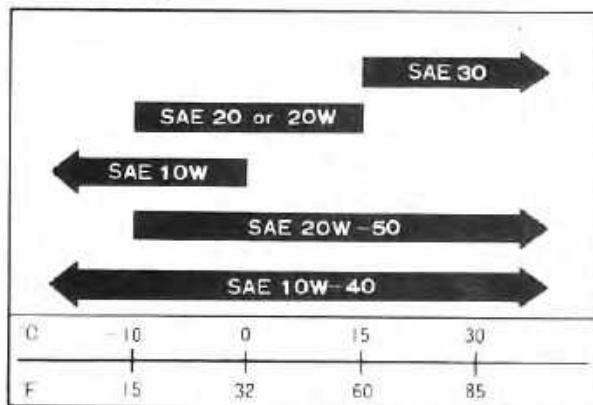

Fig. 2-5

4. MAINTENANCE PROCEDURES

Transmission Oil

Transmission oil level

To check the oil level and add oil:

1. Place the motorcycle in an upright position and remove the oil check bolt.
2. The oil should flow out of the oil check bolt hole. After checking, tighten the oil check bolt securely.
3. If the oil does not flow out, add oil slowly through the oil filler hole until the oil starts to flow out of the oil check bolt hole.

Transmission oil change

When changing oil, drain the used oil from the crankcase while the engine is warm. This will ensure complete and rapid draining.

1. Start the engine and warm it up for about three minutes.
2. Remove the oil filler cap from the left crankcase cover.
3. Place an oil drain pan under the engine to catch the oil, and then remove the drain plug with a 17 mm wrench. Rock the motorcycle from side to side to drain all residual oil.
4. When the oil has been completely drained, ensure that the drain plug sealing washer is in good condition and reinstall the drain plug.
5. Pour the recommended oil (approximately 0.5ℓ, 0.5 US qt.) slowly through the oil filler hole. Place the motorcycle in an upright position and check the oil level. Refer to the oil level checking section.

NOTE:

When reassembling the engine, add oil until it flows out of the oil check bolt hole. It takes approximately 0.75ℓ (0.8USqt) to fill a dry transmission.

Transmission oil recommendation

USE HONDA 4-STROKE OIL OR EQUIVALENT

Use only high detergent, premium quality motor oil certified to meet or exceed US automobile manufacturer's requirements for Service Classification SE. Motor oils intended for Service SE will show this designation on the container.

Viscosity selection should be based on the average atmospheric temperature in your riding area. Change to the proper viscosity oil whenever the average atmospheric temperature changes substantially.

Spark Plug**Standard plug:**

U.S.A. model: (CHAMPION) N-2G or (NGK) B9EV

Canadian model: (CHAMPION) QN-2G,
(NGK) BR9EV or (ND) W27ESR-G

If replacing with any other make of spark plug, be certain to select the correct reach and heat range. Before removing the spark plug, clean the spark plug area thoroughly to prevent dirt from entering the cylinder.

1. Measure spark plug gap with a wire gauge, and adjust by carefully bending the side electrode. The recommended spark plug gap is **0.5-0.6 mm (0.020-0.024 in.)**
2. Check the electrode for wear or deposits; the gasket for cracks or damage, and the insulator for cracks.
3. Inspect the firing tip of the used spark plug. The electrodes and insulator nose should appear tan or medium gray. To obtain accurate spark plug readings, switch the ignition off at operating speed, coast to a stop with the clutch disengaged, then remove and inspect the spark plug. Idling or low speed operation will produce darker spark plug coloration or increased fouling. If the electrodes appear burnt, or the insulator nose is white or very light gray, this indicates one or more of the following conditions:

Spark plug heat range too hot
Ignition timing excessively advanced
Fuel mixture too lean
Insufficient oil in fuel mixture

If the electrodes and insulator nose are black or fouled, this indicates one or more of the following conditions:

Spark plug heat range too cold
Ignition timing retarded
Fuel mixture too rich
Excessive or improper oil in fuel mixture

4. Install the spark plug by hand until finger tight, then tighten with a spark plug wrench until the sealing gasket is compressed (1/2 to 3/4 turn to compress a new spark plug gasket).

CAUTION

The use of a spark plug of the incorrect reach or heat range can cause engine damage.

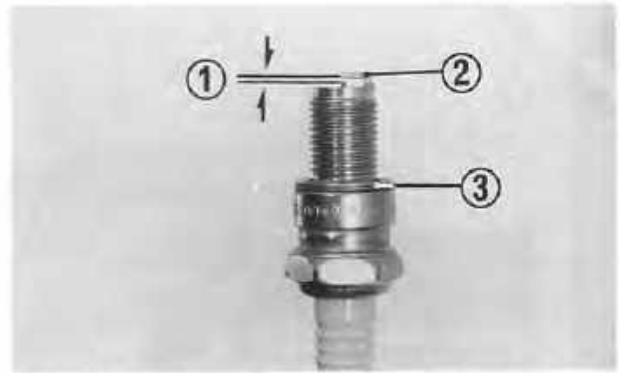

Fig. 2-6 (1) Plug gap (2) Side electrode (3) Sealing gasket



Fig. 2-7 (1) Electrodes



Fig. 2-8 (1) Spark plug wrench

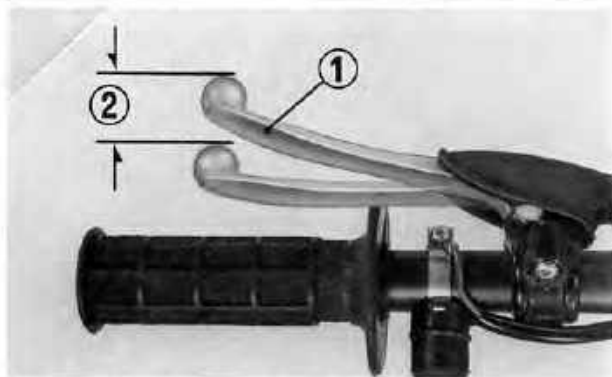

Fig. 2-9 (1) Clutch lever (2) Clutch lever free play

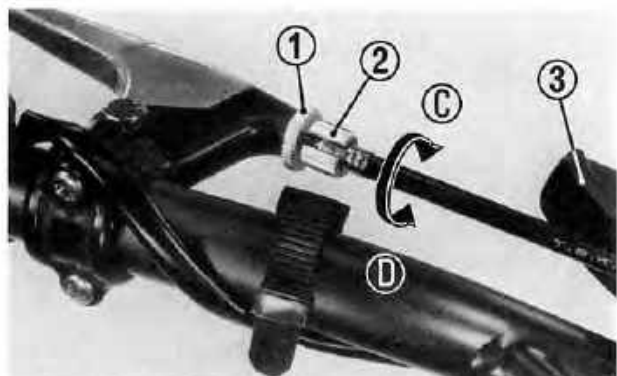

Fig. 2-10 (1) Lock nut (2) Adjuster (3) Dust cover

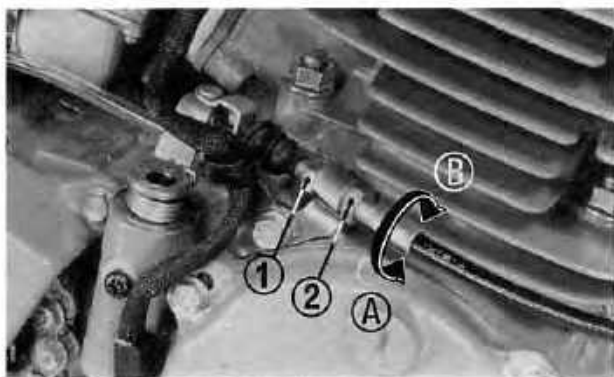

Fig. 2-11 (1) Lock nut (2) Adjusting nut

Clutch

Clutch lever free play

1. The normal clutch lever free play is 10-20 mm (3/8-3/4 in.) at the tip of the lever.
2. Minor adjustments can be made with the upper adjuster. Remove the dust cover, loosen the lock nut and turn the upper adjuster. Turning the adjuster in direction (C) will increase the free play and turning in direction (D) will decrease the free play. If the adjuster is threaded out near its limit or the correct free play can not be reached, turn the adjuster all the way in. Tighten the lock nut and install the cover.
3. Make major adjustments at the lower adjuster. Loosen the lock nut and turn the adjuster. Turning the adjusting nut in direction (A) will increase the free play and turning it in direction (B) will decrease the free play. Tighten the lock nut after adjusting.
4. Test ride to be sure the clutch operates properly without slip or drag.

Ignition Check

C.D.I. (Capacitive Discharge Ignition) system is used in this motorcycle.

Ignition timing adjustment is not necessary, since contact breaker points are not used.

Ignition timing check

1. Remove the inspection hole cap and verify correct ignition timing with a stroboscopic timing light.
2. With the engine running at **7500 rpm**, direct the beam of the timing light to the "F" mark on the rotor and see if it is aligned with the index mark on the right crankcase.
If ignition timing is incorrect, replace the A.C. generator or C.D.I. unit.
A.C. generator inspection.....Page 58

NOTE:

When the engine speed is 7500 rpm, the correct ignition timing is $15^{\circ} \pm 2^{\circ}$ BTDC.

C.D.I. Unit

1. Check the C.D.I. unit and A.C. generator for loose connections or entry of mud or water.
C.D.I. unit inspection.....Page 58

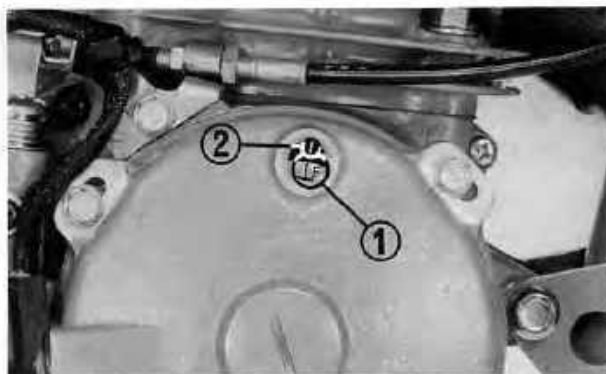

Fig. 2-12 (1) "F" mark (2) Index mark

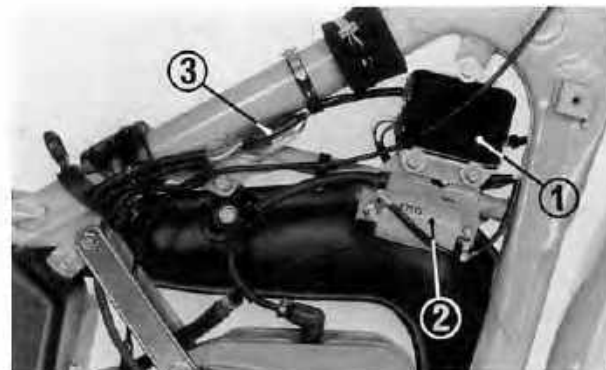

Fig. 2-13 (1) C.D.I. unit (2) Ignition coil (3) Connector

Cylinder Head, Cylinder

Disassembly and assembly III-3

Carbon deposits which build up in the combustion chamber and exhaust pipe will decrease engine performance. These carbon deposits must be removed periodically.

1. Remove the carbon deposits from the combustion chamber using a scraper of soft material and check for cracks or pin holes.
2. Remove the carbon deposits from the exhaust port in the cylinder and check the cylinder wall for wear or damage.

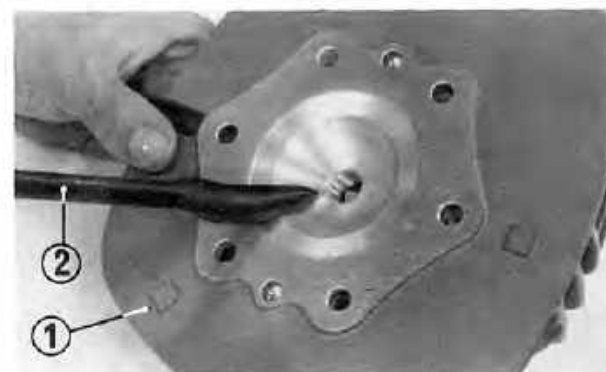

Fig. 2-14 (1) Cylinder head (2) Scraper

Piston, Piston Ring

1. Remove the carbon deposits from the piston crown. Check the piston for wear, damage or sticking rings and check the piston pin boss for cracks.
2. Check the piston rings for wear or damage.

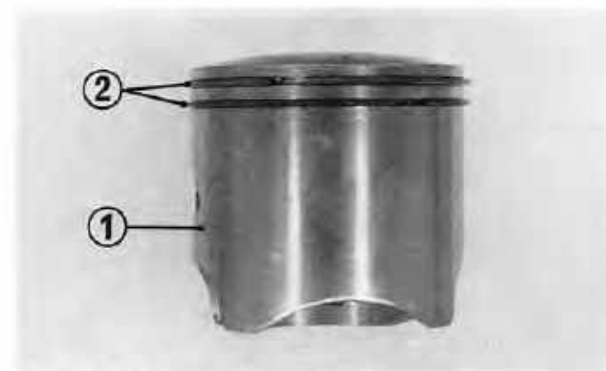

Fig. 2-15 (1) Piston (2) Piston rings

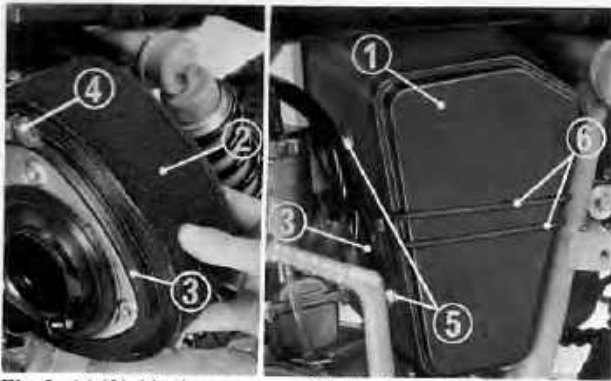

Fig. 2-16 (1) Air cleaner cover (2) Air cleaner element (3) Band
(4) Screw (5) Element holder bolts (6) Rubber strap

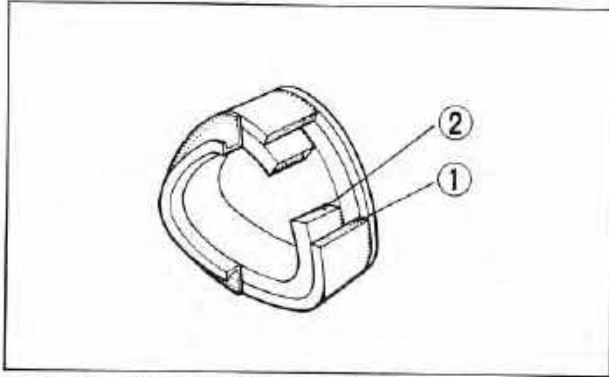

Fig. 2-17 (1) Outer element (2) Inner element

Air cleaner

The air cleaner uses a polyurethane element. A dirty element will reduce engine output. To clean the element:

1. Remove the left side cover.
2. Remove the rubber strap and air cleaner cover.
3. Remove the 3 element holder bolts. Loosen the screw on the band at the rear of the carburetor and remove the element and holder assembly.
4. Loosen the screw on the band around the element and remove it.
5. Wash the element in clean solvent and allow it to dry thoroughly.
6. Soak the element in clean gear oil (SAE #80 or #90) and squeeze out the excess.
7. Apply a thin coat of grease to the element sealing surface.
8. Reinstall the element on the element holder and tighten the band screw.
9. Reinstall the element and holder assembly with the element holder bolts. Tighten the band at the rear of the carburetor and install the cover.

WARNING

Never use gasoline or low flash point solvents for cleaning the air cleaner element. A fire or explosion could result.

CAUTION

If the element is not installed on the element holder correctly, dirt and dust may enter, resulting in rapid wear of the piston rings and cylinder.

NOTE:

The element is of a dual construction, inner and outer. Wash both elements thoroughly in solvent.

Handlebars

1. Check the handlebars for bends or cracks.
2. Check the upper holders for correct tightness.
3. Check the steering for play.
4. Turn the handlebars to the right and left to check for smooth operation.

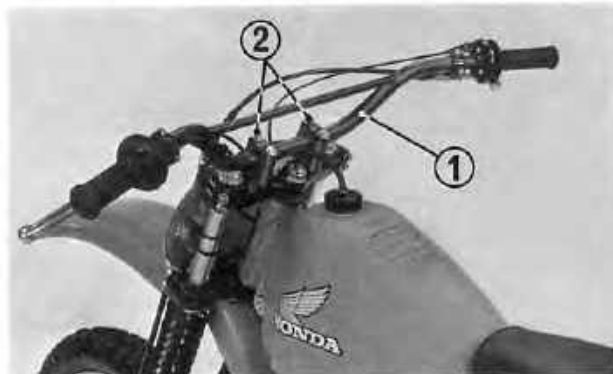

Fig. 2-18 (1) Handlebar (2) Handlebar upper holder

Throttle Grip

1. The standard throttle grip free play is 5–10 mm (3/16–3/8 in) of grip rotation.
2. To adjust, pull up the rubber cap and loosen the lock nut. Turn the adjuster in direction (A) to decrease free play, and in direction (B) to increase free play. Tighten the lock nut and reinstall the rubber cap securely after adjustment.



Fig. 2-19 (1) Lock nut (2) Adjuster (3) Rubber cap

3. Minor adjustment is made by the upper adjuster. Remove the dust cover and loosen the lock nut. Turning the adjuster in direction (C) will decrease the free play and turning it in direction (D) will increase the free play.

NOTE:

Tighten the lock nut and install the dust cover after adjustment is completed.

4. Operate the throttle grip to ensure that it functions smoothly.

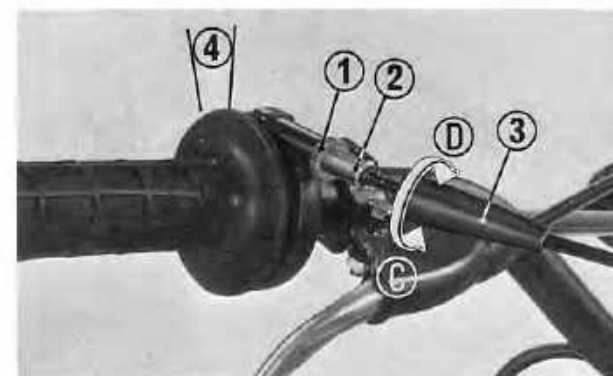

Fig. 2-20 (1) Lock nut (2) Adjuster (3) Dust cover (4) Grip free play

Front and Rear Wheels

1. Check the axle shaft for bend.
2. Check the for condition of the hub bearings.
3. Check the for runout of the wheel rims.
4. Check the spokes for looseness.
5. Tighten loose rim locks.
6. Inspect tires for wear or damage.
7. Check tire pressure:

Front: 1.2 kg/cm² (17.0 psi)

Rear: 1.2 kg/cm² (17.0 psi)

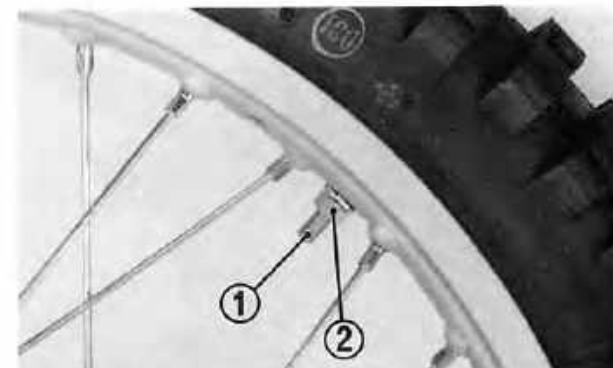

Fig. 2-21 (1) Rim lock (2) Lock nut

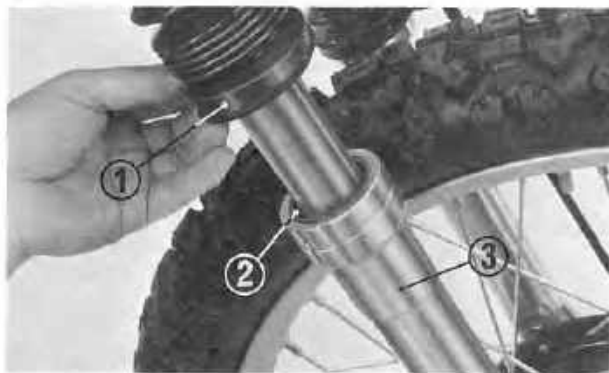

Fig. 2-22 (1) Fork boot
(2) Dust seal
(3) Fork slider

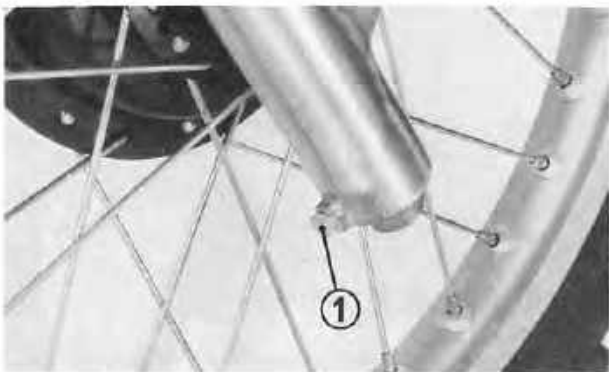

Fig. 2-23 (1) Drain plug

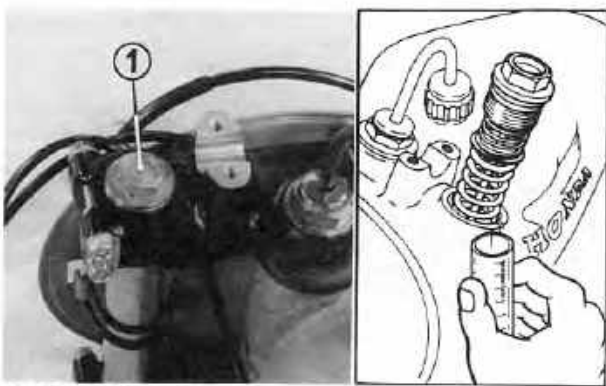

Fig. 2-24 (1) Fork bolt



Fig. 2-25 (1) Handlebar (2) Handle upper holder

Front Fork

1. Check for operation.
2. Check the fork seal for oil leakage.
3. Check for accumulation of dirt in the boots.

Front fork oil change

1. Remove the drain plugs.
2. Allow both forks to drain completely by pumping several times.

3. Install the drain plugs and tighten securely.
4. Remove the handlebar by removing the handlebar upper holders.
5. Loosen the fork bolts and slide the forks down about 50 mm (2 in)
6. Fill each fork with the specified amount of oil.

Fork oil capacity: 205 cc (6.9 ozs) each leg
 at draining
 275 cc (9.3 ozs) each leg
 at dry assembly

Fork oil specification: Fork oil SAE #5W

7. Raise the front forks up and tighten the fork bolts.
8. Install the handlebars (see page 47).

Rear Suspension

1. Check the shock absorber spring for fatigue.
2. Check the shock absorber for damage.
3. Check the shock absorber bushings for deterioration.
4. Check the operation by pumping.
5. Check the rear shock absorber shaft for bends.
6. Inspect the swing arm bearings for play by checking the side play at the rear wheel.

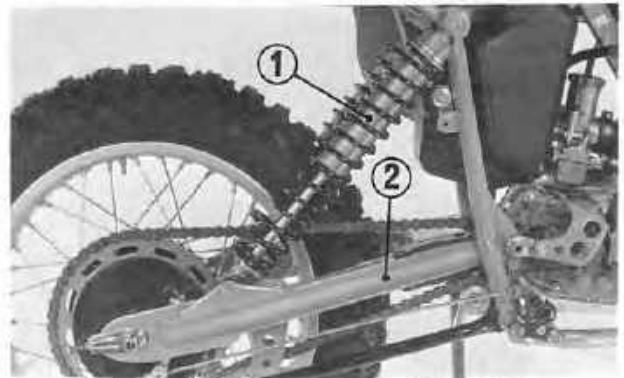

Fig. 2-26 (1) Rear shock absorber (2) Rear fork

Rear suspension adjustment

Rear suspension spring tension is adjustable in three increments to suit riding conditions and rider's weight.

1. Press the spring down and position the stopper ring in the desired setting groove.
- Be certain that both right and left springs are adjusted to identical settings.

NOTE:

The position "I" is the standard.

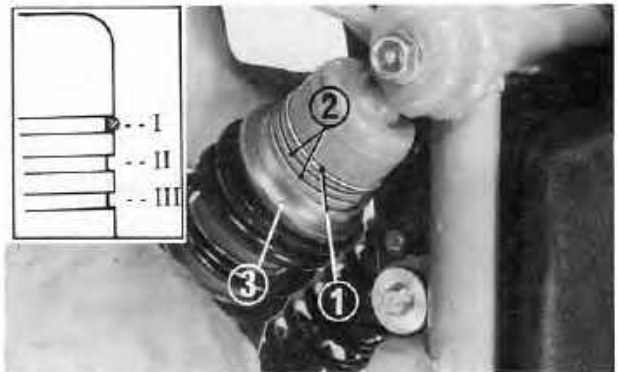

Fig. 2-27 (1) Stopper ring (2) Setting groove (3) Spring adjuster

Front Brake

1. Check the brake drum for wear.
2. Check the brake shoes for wear.
3. Check the brake cam for wear.
4. Check the brake lever for free play.

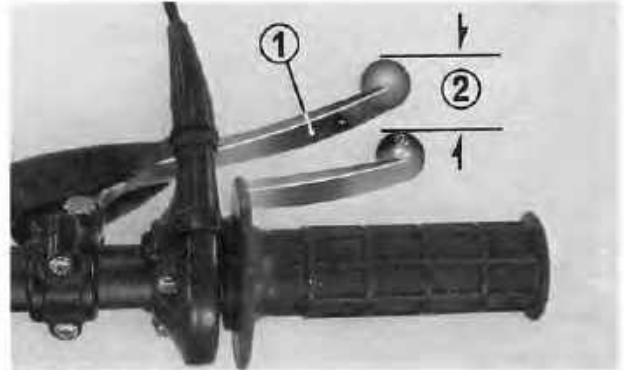

Fig. 2-28 (1) Front brake lever (2) Free play

Front brake adjustment

Free play, measured at the tip of the front brake lever, should be maintained at 20-30 mm (3/4-1-3/8 in.).

Free play is the distance the brake lever moves before the brake starts to engage.

1. Major adjustments should be made using the adjusting nut located at the front wheel.

Loosen the lock nut and turn the front brake adjusting nut. Turning the adjusting nut in direction (A) will increase the brake lever free play and turning the nut in direction (B) will decrease the free play.

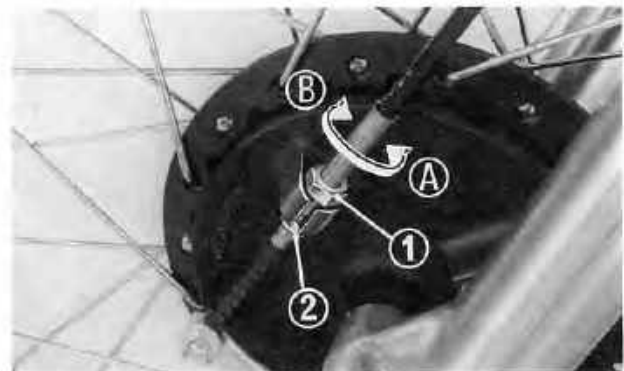

Fig. 2-29 (1) Lock nut (2) Adjusting nut

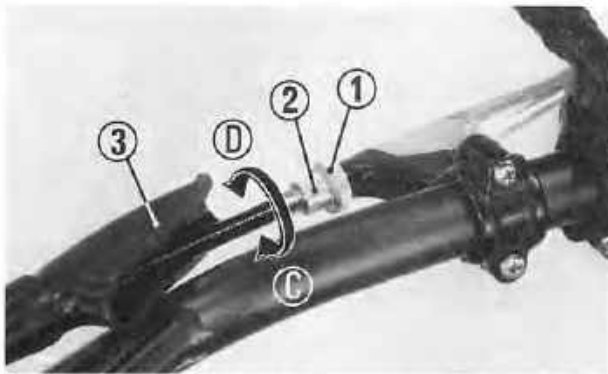

Fig. 2-30 (1) Lock nut (2) Adjuster (3) Dust cover

2. Minor adjustments can be made with the front brake cable adjuster at the front brake lever.

Remove the dust cover, loosen the lock nut and turn the front brake cable adjuster. Turning the adjuster in direction (C) will increase the brake lever free play and turning the adjuster in direction (D) will decrease the free play.

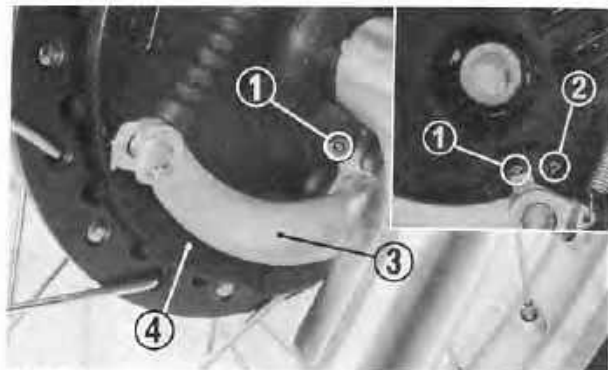

Fig. 2-31 (1) Arrow mark (3) Brake arm
(2) Reference mark (4) Brake panel

Brake wear indicator

A wear indicator is provided in the front brake. When the brake is applied, an arrow, adjacent to the brake arm, moves toward a reference mark on the brake panel. The distance between the arrow and the reference mark, on full application of the brake, indicates brake lining condition.

If the arrow aligns with the reference mark on full application of the brake, replace the brake shoes.

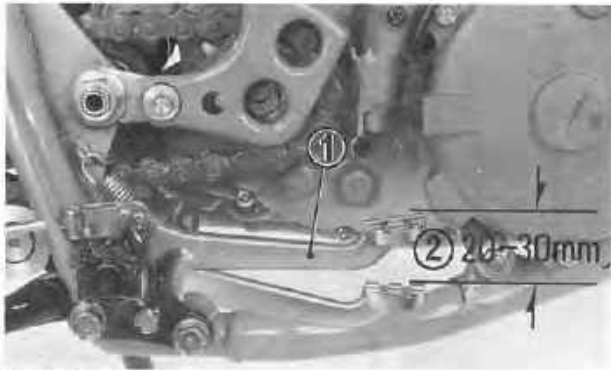

Fig. 2-32 (1) Brake pedal (2) Free play

Rear Brake

1. Check the brake drum, brake shoes and brake cam for wear.
2. Check the brake pedal for operation.
3. Check the brake pedal free play.



Fig. 2-33 (1) Adjuster

Rear brake adjustment

Rear brake pedal free play, measured at the tip of the rear brake pedal, should be maintained at 20-30 mm (3/4-1-3/8 in.).

Free play is the distance the brake pedal moves before the brake starts to engage:

1. To adjust rear brake pedal free play turn the adjuster. Turning the adjuster in direction (A) will increase the free play and turning it in direction (B) will decrease the free play.

Brake wear indicator

A wear indicator is provided in the rear brake. When the brake is applied, an arrow, adjacent to the brake arm, moves toward a reference mark on the brake panel. The distance between the arrow and the reference mark, on full application of the brake, indicates brake lining condition. If the arrow aligns with the reference mark on full application of the brake, replace the brake shoes.

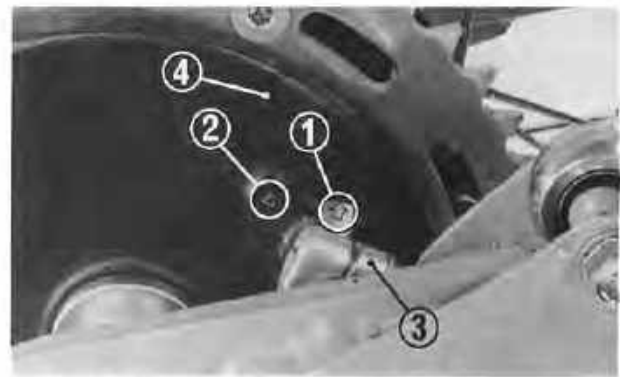

Fig. 2-34 (1) Arrow mark (3) Brake arm
(2) Reference mark (4) Brake panel

Drive Chain Maintenance

Proper adjustment and lubrication will help to extend the service life of the drive chain. Place a wood block under the engine to raise the rear wheel off the ground. Shift the transmission into neutral. The engine should be stopped. Then, turn the rear wheel slowly and check the drive chain and sprockets for any of the following conditions:

Drive Chain:

- Damaged rollers
- Loose pins
- Dry and rusted links
- Kinked and binding links
- Excessive wear
- Improper adjustment

Sprockets:

- Excessively worn teeth
- Broken or damaged teeth



Fig. 2-35 (1) Drive chain

Measuring drive chain wear

Measure a section of the drive chain to determine whether the chain is worn beyond its service limit. Put the transmission in gear, and then turn the rear wheel forward until the lower section of the chain is pulled taut. With the chain held taut and any kinked joints straightened, measure the distance between a span of 17 pins, from pin center to pin center. After the chain is measured, shift the transmission into neutral again before proceeding with inspection and service.

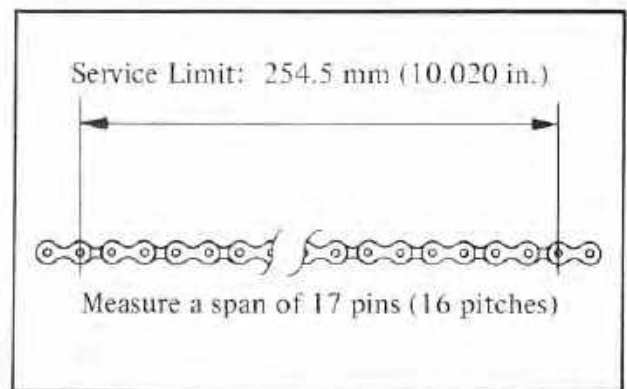

Fig. 2-36

Inspecting the sprockets

Check the drive and driven sprockets for wear or damage. The right rear crankcase cover must be removed for access to the drive sprocket. Excessively worn sprocket teeth have a hooked, asymmetrical appearance. Replace any sprocket which is damaged or excessively worn.

NOTE:

Never install a new drive chain on badly worn sprockets, or use new sprockets with a badly worn drive chain. Both chain and sprockets must be in good condition, or the new replacement chain or sprocket will wear rapidly.

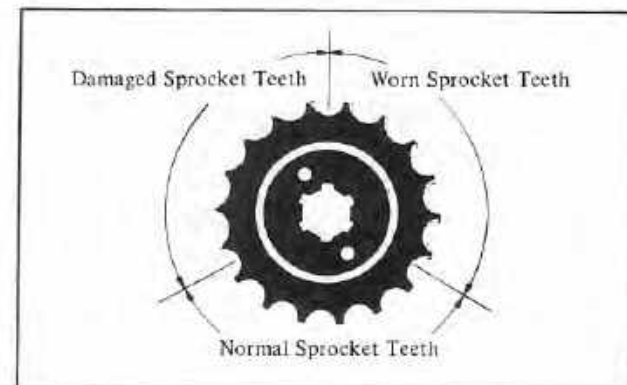

Fig. 2-37



Fig. 2-38 (1) Chain tensioner roller
(2) Chain guide roller
(3) Chain slack

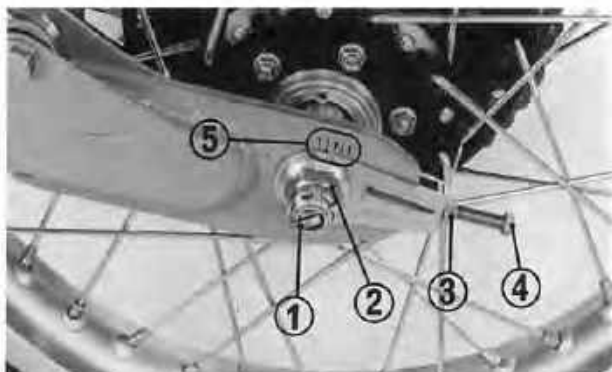

Fig. 2-39 (1) Cotter pin (2) Rear axle nut (3) Lock nut
(4) Adjusting bolt (5) Index mark

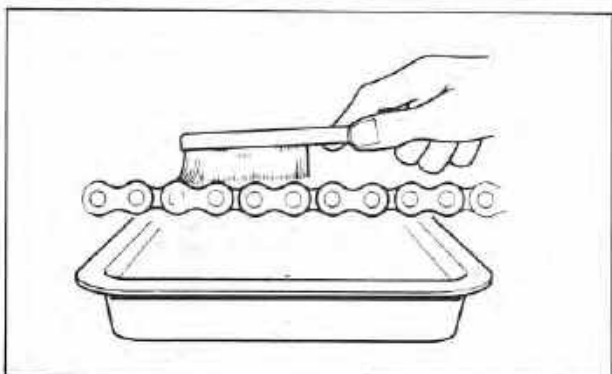

Fig. 2-40

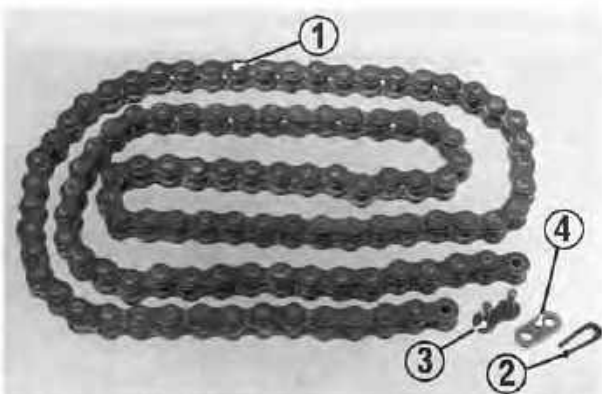

Fig. 2-41 (1) Drive chain (2) Retaining clip (3) Master link
(4) Link plate

Measuring drive chain slack

Check drive chain slack at a point midway between the chain tensioner roller and chain guide roller. Move the chain up and down by hand, and measure the amount of slack.

Drive chain slack: 13 mm (1/2 in.)

Drive chain tension should remain constant as the wheel is rotated.

If the chain is found to be slack in one segment of its length and taut in another, this indicates that some of the links are either worn or kinked and binding. Kinking and binding can frequently be eliminated by lubrication.

Drive chain adjustment

If the drive chain is found to require adjustment, the procedure is as follows:

1. Remove the rear axle nut cotter pin and loosen the rear axle nut.
2. Loosen the lock nuts and turn the adjusting bolts to increase or decrease chain tension. Align the chain adjuster index marks to the reference marks on both sides of the swing arm.
3. Tighten the rear axle nut and secure the nut with the cotter pin.

Specified torque: 8.0–10.0 kg-m (57.9–72.3 lb-ft)

CAUTION

Always replace used cotter pins with new ones.

4. Tighten the adjusting bolts and secure them with the lock nuts.

Lubrication

Commercially prepared drive chain lubricants may be purchased at most motorcycle shops and should be used in preference to motor oil or other lubricants.

Saturate each chain joint so that the lubricant will penetrate the space between adjacent surfaces of link plates and rollers.

Removal and cleaning

When the drive chain becomes extremely dirty, it should be removed and cleaned prior to lubrication.

1. Carefully remove the master link retaining clip with pliers. Do not bend or twist the clip. Remove the master link. Remove the drive chain from the motorcycle.
2. Clean the drive chain in solvent and let it dry. Inspect the drive chain for possible wear or damage. Replace any chain that has damaged rollers, loose fitting links, or otherwise appears unserviceable.

3. Inspect the sprocket teeth for possible wear or damage. Replace if necessary. Never use a new drive chain on badly worn sprockets. Both chain and sprockets must be in good condition, or the new replacement chain or sprocket will wear rapidly.
4. Lubricate the drive chain.
5. Pass the chain over the sprockets and join the ends of the chain with the master link. For ease of assembly, hold the chain ends against adjacent rear sprocket teeth while inserting the master link. Install the master link retaining clip so that the closed end of the clip will face the direction of forward wheel rotation. The master link is the most critical part affecting the security of the drive chain. Master links are reusable, if they remain in excellent condition, but it is recommended that a new master link retaining clip be installed whenever the drive chain is reassembled.
6. Adjust the drive chain to the proper tension, following the instruction on page 18.

Chain Tensioner Roller, Chain Guide Roller

1. Check the rollers for wear.

Chain Tensioner Roller O.D. Service Limit: 25 mm (0.9 in.)

Chain Guide Roller O.D. Service Limit: 25 mm (0.9 in.)

2. Check for lubrication.

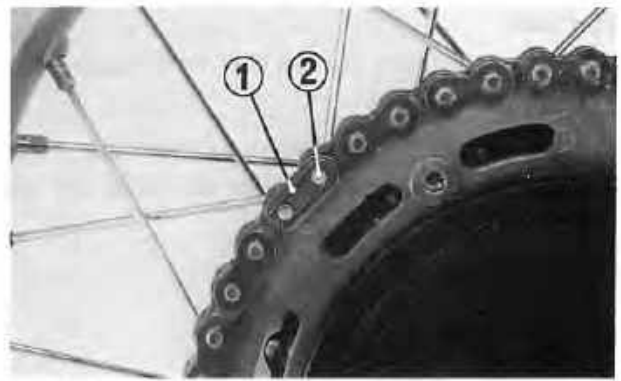

Fig. 2-42 (1) Retaining clip (2) Master link

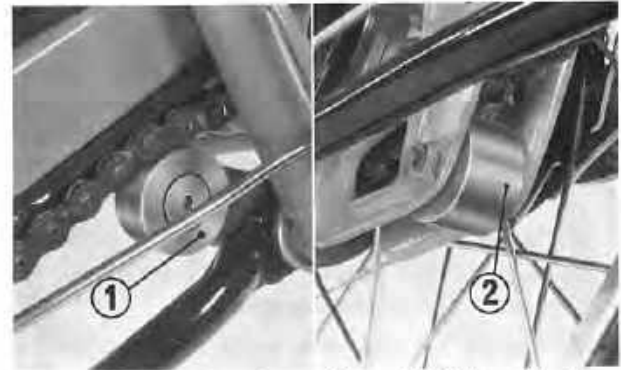

Fig. 2-43 (1) Chain tensioner roller (2) Chain guide roller

Chain Guide

1. Check the chain guide alignment and condition.

CAUTION

Check alignment of the chain guide. If the chain guide should become bent, it may rub against the drive chain and cause rapid wear.

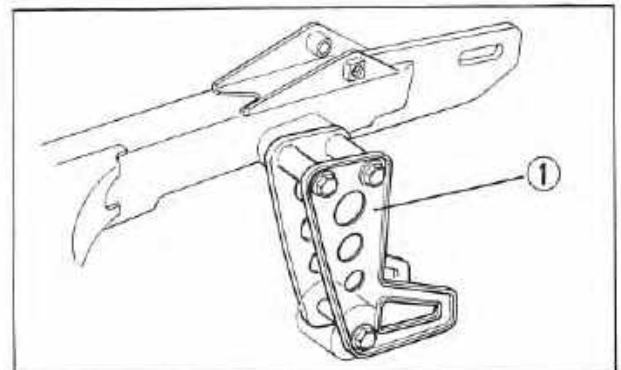

Fig. 2-44 (1) Chain guide

Chain Slider

1. Check the chain slider for wear.

CAUTION

If the chain slider becomes worn so that the swing arm is exposed, the chain may rub against the swing arm and cause rapid wear.

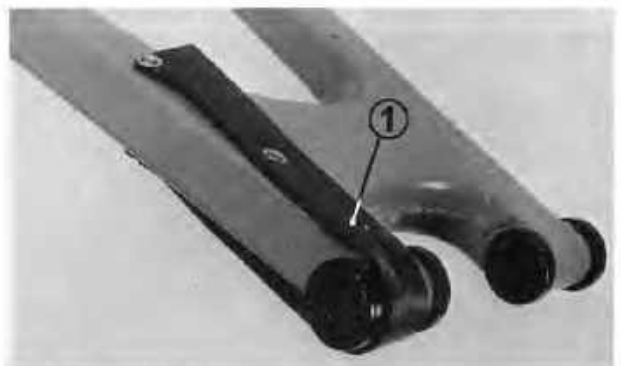

Fig. 2-45 Chain slider

Fuel Tank

1. Check the fuel valve and fuel filter for contamination.
2. Check for leaks.
3. Check the fuel line for cracks or deterioration.
4. Check for interference between the frame and tank and adjust if necessary.



Fig. 2-46 (1) Fuel tank (2) Fuel line

Fuel Filter

The fuel filter is incorporated in the fuel valve which is mounted on the bottom of the fuel tank at the right side. Accumulation of dirt in the filter will restrict the flow of the fuel to the carburetor. Therefore, the fuel filter should be serviced periodically.

1. Drain the fuel from the fuel tank. Disconnect the fuel line.
2. Remove the fuel valve by removing the screws. Wash the fuel screen filter in cleaning solvent.
3. Reassemble the fuel valve in the reverse order of removal and turn the fuel valve to "ON" and check for leaks.

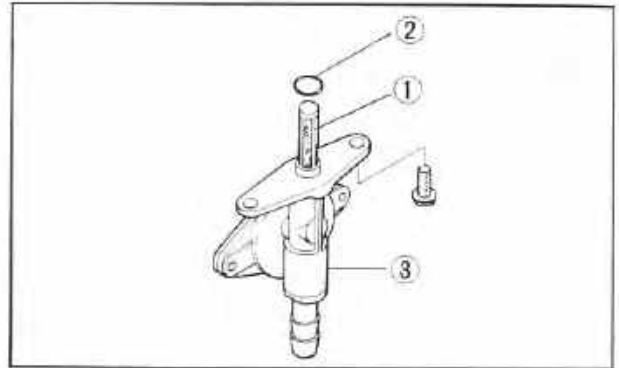

Fig. 2-47 (1) Fuel filter (2) O-ring (3) Fuel valve

WARNING

- * Gasoline is extremely flammable and is explosive under certain conditions. Perform this operation in a well ventilated area and do not smoke or allow open flames or sparks in the area.

Expansion Chamber

1. Check the three exhaust pipe springs, and replace if they are damaged or stretched.
2. Check the chamber bolts for tightness.
3. Remove carbon deposits from the throat of the exhaust pipe.
4. Check the expansion chamber for cracks or deformation.
A damaged chamber may cause an excessive drop in engine horsepower.

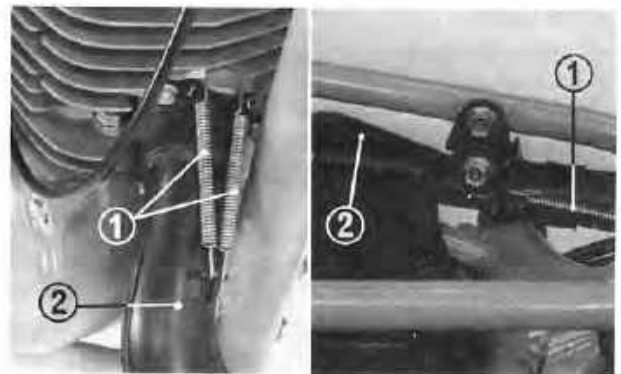

Fig. 2-48 (1) Spring (2) Expansion chamber

Brake wear indicator

A wear indicator is provided in the rear brake. When the brake is applied, an arrow, adjacent to the brake arm, moves toward a reference mark on the brake panel. The distance between the arrow and the reference mark, on full application of the brake, indicates brake lining condition. If the arrow aligns with the reference mark on full application of the brake, replace the brake shoes.

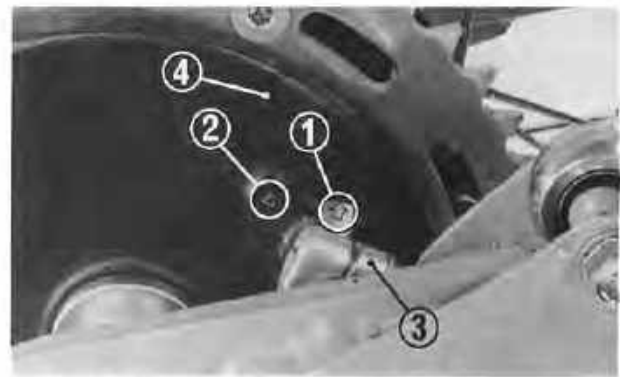

Fig. 2-34 (1) Arrow mark (3) Brake arm
(2) Reference mark (4) Brake panel

Drive Chain Maintenance

Proper adjustment and lubrication will help to extend the service life of the drive chain. Place a wood block under the engine to raise the rear wheel off the ground. Shift the transmission into neutral. The engine should be stopped. Then, turn the rear wheel slowly and check the drive chain and sprockets for any of the following conditions:

Drive Chain:

- Damaged rollers
- Loose pins
- Dry and rusted links
- Kinked and binding links
- Excessive wear
- Improper adjustment

Sprockets:

- Excessively worn teeth
- Broken or damaged teeth



Fig. 2-35 (1) Drive chain

Measuring drive chain wear

Measure a section of the drive chain to determine whether the chain is worn beyond its service limit. Put the transmission in gear, and then turn the rear wheel forward until the lower section of the chain is pulled taut. With the chain held taut and any kinked joints straightened, measure the distance between a span of 17 pins, from pin center to pin center. After the chain is measured, shift the transmission into neutral again before proceeding with inspection and service.

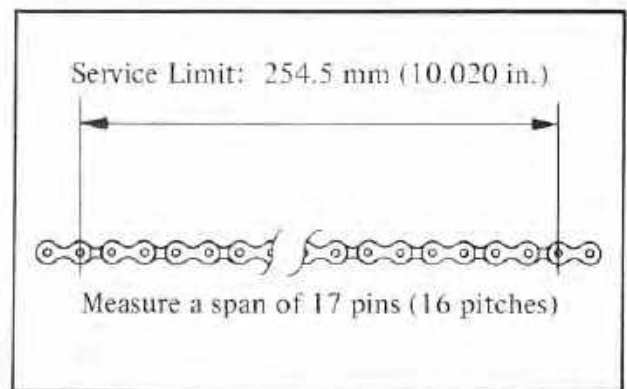

Fig. 2-36

Inspecting the sprockets

Check the drive and driven sprockets for wear or damage. The right rear crankcase cover must be removed for access to the drive sprocket. Excessively worn sprocket teeth have a hooked, asymmetrical appearance. Replace any sprocket which is damaged or excessively worn.

NOTE:

Never install a new drive chain on badly worn sprockets, or use new sprockets with a badly worn drive chain. Both chain and sprockets must be in good condition, or the new replacement chain or sprocket will wear rapidly.

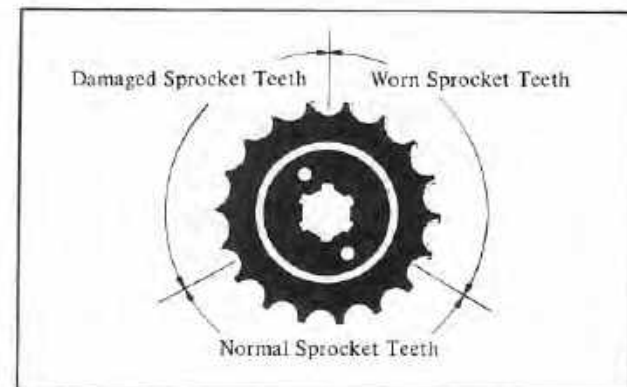

Fig. 2-37



Fig. 2-38 (1) Chain tensioner roller
(2) Chain guide roller
(3) Chain slack

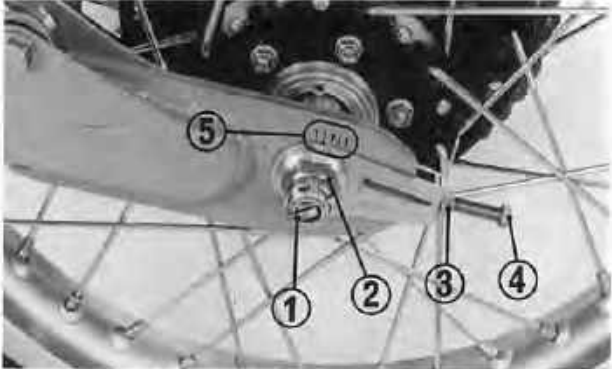

Fig. 2-39 (1) Cotter pin (2) Rear axle nut (3) Lock nut
(4) Adjusting bolt (5) Index mark

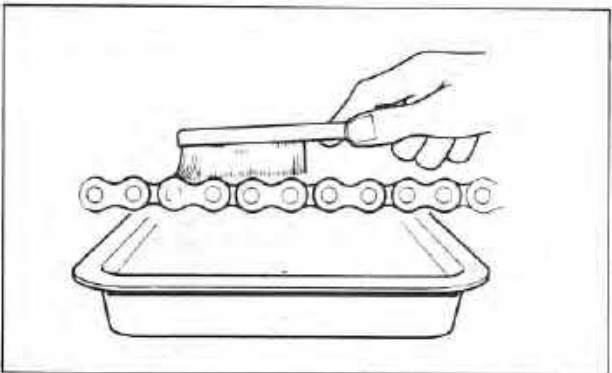

Fig. 2-40

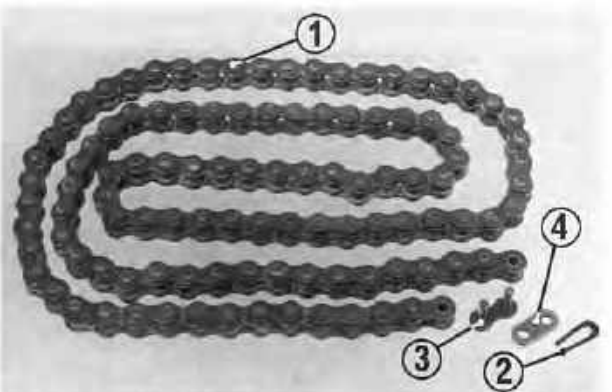

Fig. 2-41 (1) Drive chain (2) Retaining clip (3) Master link
(4) Link plate

Measuring drive chain slack

Check drive chain slack at a point midway between the chain tensioner roller and chain guide roller. Move the chain up and down by hand, and measure the amount of slack.

Drive chain slack: 13 mm (1/2 in.)

Drive chain tension should remain constant as the wheel is rotated.

If the chain is found to be slack in one segment of its length and taut in another, this indicates that some of the links are either worn or kinked and binding. Kinking and binding can frequently be eliminated by lubrication.

Drive chain adjustment

If the drive chain is found to require adjustment, the procedure is as follows:

1. Remove the rear axle nut cotter pin and loosen the rear axle nut.
2. Loosen the lock nuts and turn the adjusting bolts to increase or decrease chain tension. Align the chain adjuster index marks to the reference marks on both sides of the swing arm.
3. Tighten the rear axle nut and secure the nut with the cotter pin.

Specified torque: 8.0–10.0 kg-m (57.9–72.3 lb-ft)

CAUTION

Always replace used cotter pins with new ones.

4. Tighten the adjusting bolts and secure them with the lock nuts.

Lubrication

Commercially prepared drive chain lubricants may be purchased at most motorcycle shops and should be used in preference to motor oil or other lubricants.

Saturate each chain joint so that the lubricant will penetrate the space between adjacent surfaces of link plates and rollers.

Removal and cleaning

When the drive chain becomes extremely dirty, it should be removed and cleaned prior to lubrication.

1. Carefully remove the master link retaining clip with pliers. Do not bend or twist the clip. Remove the master link. Remove the drive chain from the motorcycle.
2. Clean the drive chain in solvent and let it dry. Inspect the drive chain for possible wear or damage. Replace any chain that has damaged rollers, loose fitting links, or otherwise appears unserviceable.

3. Inspect the sprocket teeth for possible wear or damage. Replace if necessary. Never use a new drive chain on badly worn sprockets. Both chain and sprockets must be in good condition, or the new replacement chain or sprocket will wear rapidly.
4. Lubricate the drive chain.
5. Pass the chain over the sprockets and join the ends of the chain with the master link. For ease of assembly, hold the chain ends against adjacent rear sprocket teeth while inserting the master link. Install the master link retaining clip so that the closed end of the clip will face the direction of forward wheel rotation. The master link is the most critical part affecting the security of the drive chain. Master links are reusable, if they remain in excellent condition, but it is recommended that a new master link retaining clip be installed whenever the drive chain is reassembled.
6. Adjust the drive chain to the proper tension, following the instruction on page 18.

Chain Tensioner Roller, Chain Guide Roller

1. Check the rollers for wear.

Chain Tensioner Roller O.D. Service Limit: 25 mm (0.9 in.)

Chain Guide Roller O.D. Service Limit: 25 mm (0.9 in.)

2. Check for lubrication.

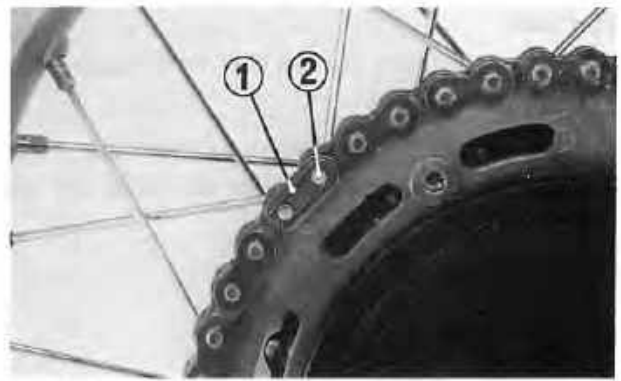

Fig. 2-42 (1) Retaining clip (2) Master link

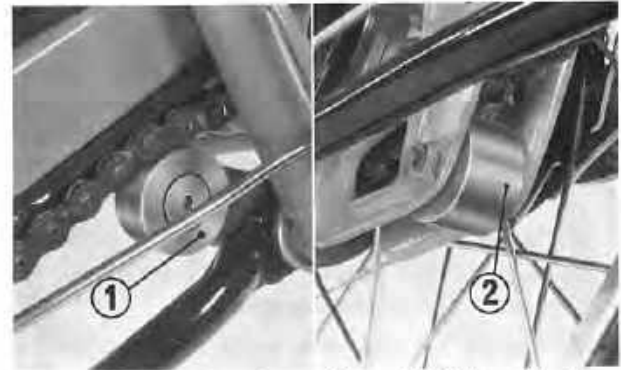

Fig. 2-43 (1) Chain tensioner roller (2) Chain guide roller

Chain Guide

1. Check the chain guide alignment and condition.

CAUTION

Check alignment of the chain guide. If the chain guide should become bent, it may rub against the drive chain and cause rapid wear.

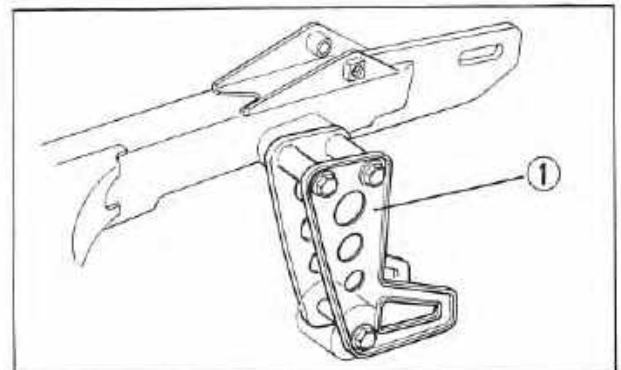

Fig. 2-44 (1) Chain guide

Chain Slider

1. Check the chain slider for wear.

CAUTION

If the chain slider becomes worn so that the swing arm is exposed, the chain may rub against the swing arm and cause rapid wear.

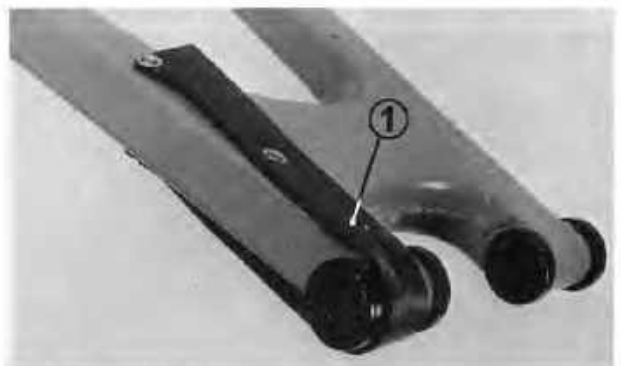

Fig. 2-45 Chain slider

Fuel Tank

1. Check the fuel valve and fuel filter for contamination.
2. Check for leaks.
3. Check the fuel line for cracks or deterioration.
4. Check for interference between the frame and tank and adjust if necessary.



Fig. 2-46 (1) Fuel tank (2) Fuel line

Fuel Filter

The fuel filter is incorporated in the fuel valve which is mounted on the bottom of the fuel tank at the right side. Accumulation of dirt in the filter will restrict the flow of the fuel to the carburetor. Therefore, the fuel filter should be serviced periodically.

1. Drain the fuel from the fuel tank. Disconnect the fuel line.
2. Remove the fuel valve by removing the screws. Wash the fuel screen filter in cleaning solvent.
3. Reassemble the fuel valve in the reverse order of removal and turn the fuel valve to "ON" and check for leaks.

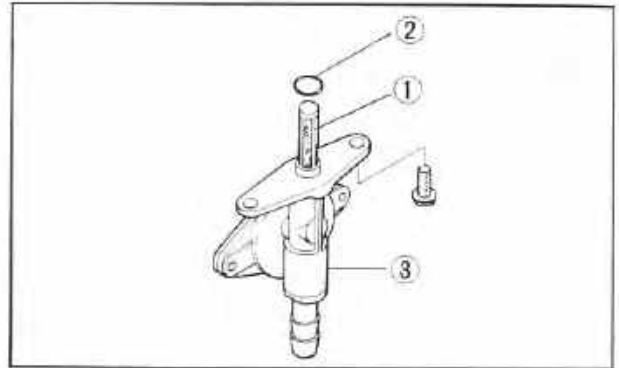

Fig. 2-47 (1) Fuel filter (2) O-ring (3) Fuel valve

WARNING

- * Gasoline is extremely flammable and is explosive under certain conditions. Perform this operation in a well ventilated area and do not smoke or allow open flames or sparks in the area.

Expansion Chamber

1. Check the three exhaust pipe springs, and replace if they are damaged or stretched.
2. Check the chamber bolts for tightness.
3. Remove carbon deposits from the throat of the exhaust pipe.
4. Check the expansion chamber for cracks or deformation. A damaged chamber may cause an excessive drop in engine horsepower.

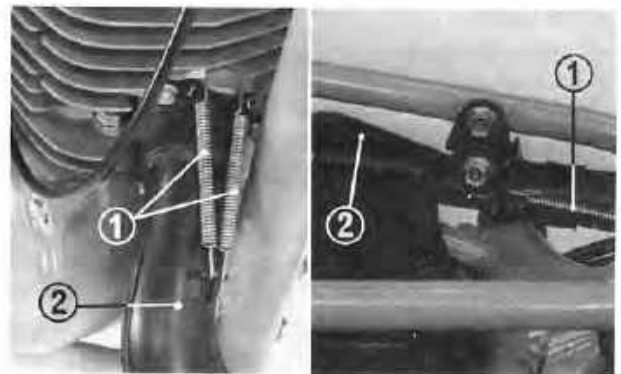

Fig. 2-48 (1) Spring (2) Expansion chamber

1. SERVICE NOT REQUIRING ENGINE REMOVAL

Parts to Be Serviced	Ref. page
Cylinder head, cylinder, piston	24
Clutch	28
Kickstarter	31
Gear shift mechanism	32
Carburetor	39
Electric system	57

2. ENGINE REMOVAL AND INSTALLATION

Engine Removal

Remove the engine from the frame as follows.

1. Remove the seat, fuel tank and left and right side covers.



Fig. 3-1 (1) Seat (2) Fuel tank (3) Left side cover

2. Remove the carburetor (Section III-9).



Fig. 3-2 (1) Carburetor insulator band
(2) Air intake tube band

3. Disconnect the AC generator wire connectors and remove the wire from the band.
Remove the spark plug cap.

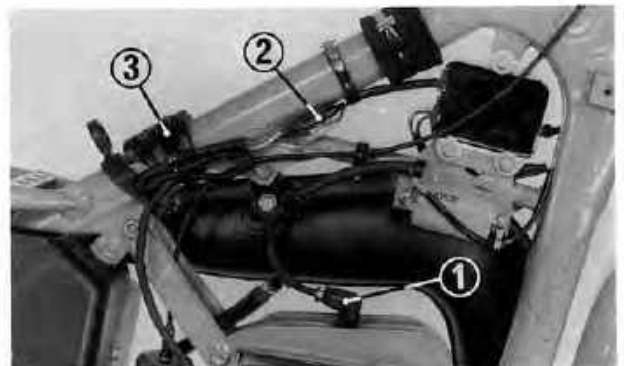

Fig. 3-3 (1) Spark plug cap (2) Connector (3) Band

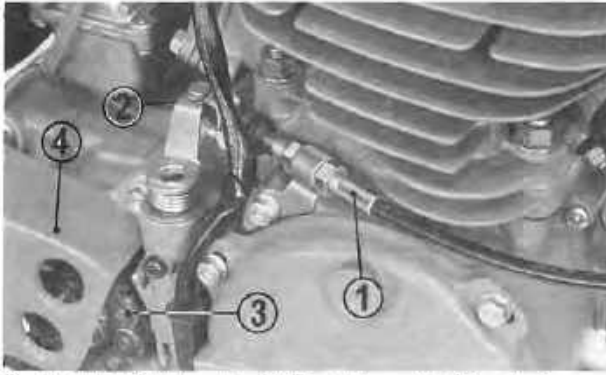

Fig. 3-4 (1) Clutch cable (2) Clutch lever (3) Drive chain
(4) Engine sprocket cover

4. Remove the engine sprocket cover.

5. Remove the drive chain by removing the retaining clip and master link.

Disconnect the clutch cable from the clutch lever on the engine.

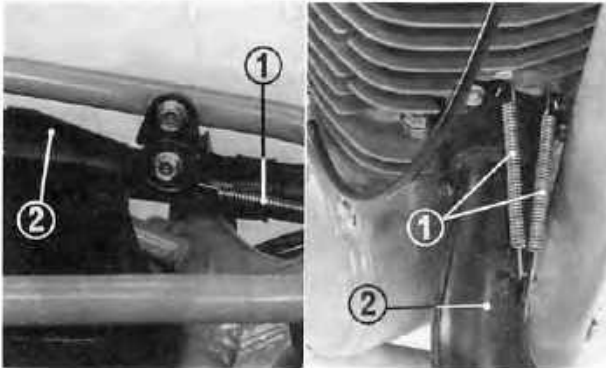

Fig. 3-5 (1) Springs (2) Expansion chamber

6. Remove the expansion chamber by removing the expansion chamber springs and mounting bolts.

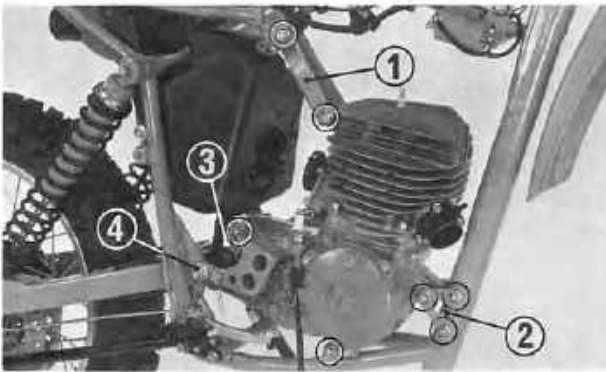

Fig. 3-6 (1) Engine upper mounting plate
(2) Engine front mounting plate
(3) Engine rear mounting (4) Swing arm pivot bolt

7. Remove the engine mounting bolts.



Fig. 3-7 (1) Swingarm pivot bolt (2) Engine mounting
(3) Nut

8. Loosen the swing arm pivot bolt and pull the engine up, then remove the mounting bolt.

Remove the engine.

Engine Installation

Install the engine in the reverse order of removal.

Specified torque:**Engine mounting**

10 mm bolts (six):	3.8–4.8 kg-m (27.5–34.7 lb-ft)
8 mm bolts (two):	1.8–2.5 kg-m (13.0–18.1 lb-ft)
Swing arm pivot bolt:	6.0–8.0 kg-m (43.4–57.9 lb-ft)

NOTE:

After installing the engine, insert the collar and rubber cushion into the sprocket cover and install the cover. Tighten the rear bolt at the frame first, then tighten the forward bolt at the engine.

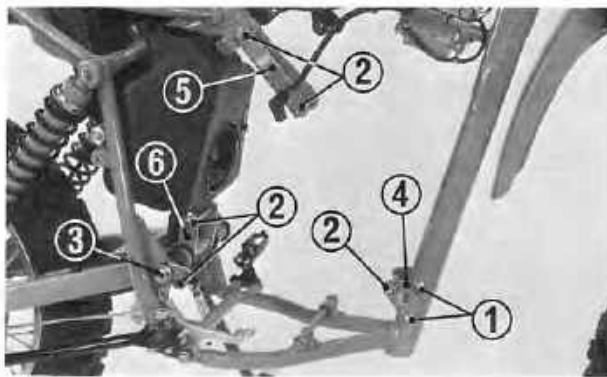
**Fig. 3-8**

- (1) 8 mm bolts (2) 10 mm bolts (3) Swingarm pivot bolt
 (4) Front mounting plate (5) Upper mounting plate
 (6) Rear mount

3. CYLINDER HEAD, CYLINDER AND PISTON

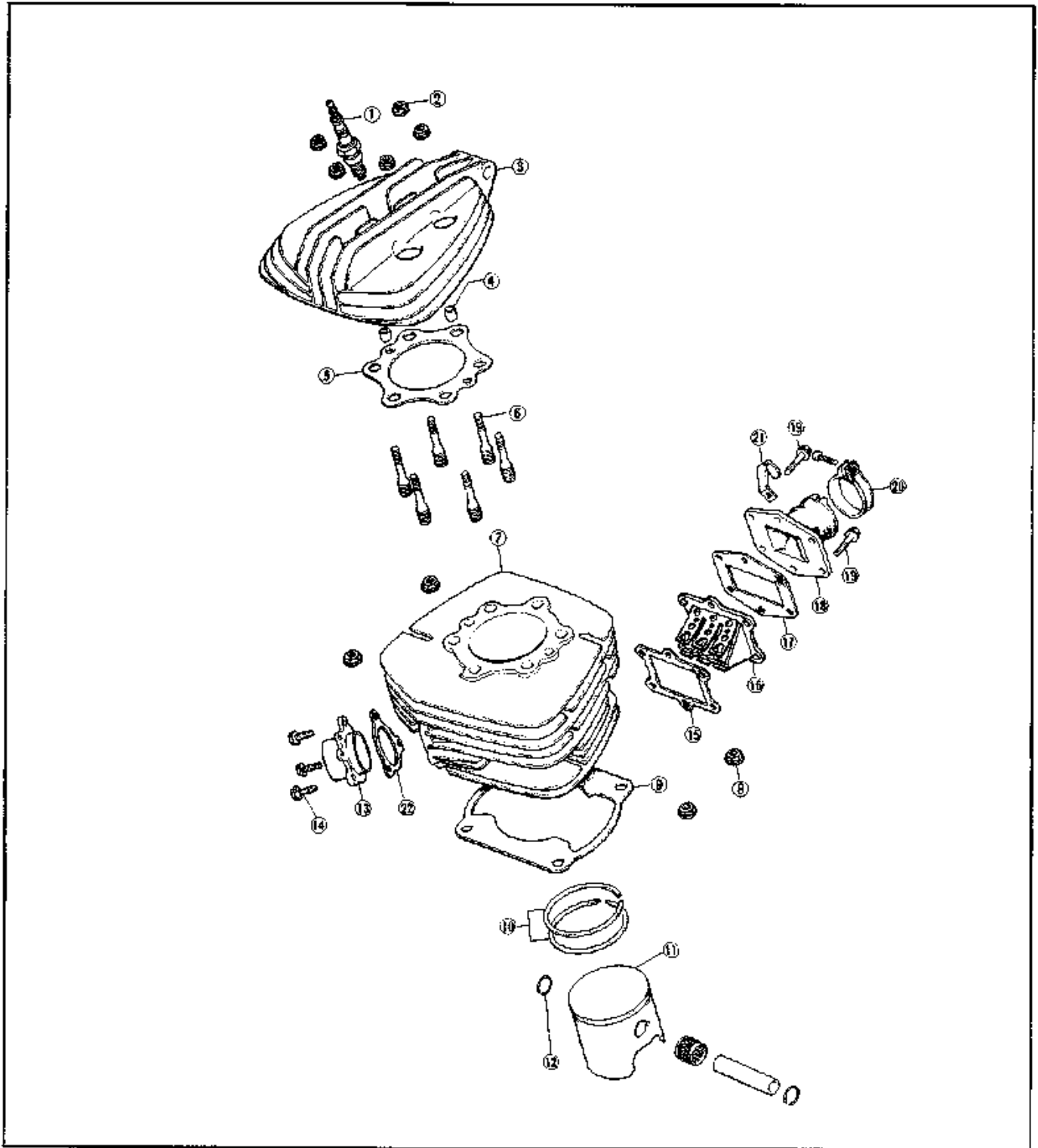

Fig. 3-9

- | | | | |
|--------------------------------|----------------------------|-------------------------------|------------------------|
| (1) Spark plug | (8) Flange nut (four) | (15) Reed valve gasket | (22) Ex. flange gasket |
| (2) Flange nut (six) | (9) Cylinder gasket | (16) Reed valve assembly | |
| (3) Cylinder head | (10) Piston ring set | (17) Intake tube gasket | |
| (4) Dowel pin (two) | (11) Piston | (18) Intake tube | |
| (5) Cylinder head gasket | (12) Piston pin clip (two) | (19) Flange bolt (six) | |
| (6) Cylinder stud bolt (six) | (13) Exhaust pipe joint | (20) Intake tube band | |
| (7) Cylinder | (14) Bolt (three) | (21) A.C. generator cord clip | |

Disassembly

1. Remove the seat.
2. Remove the fuel tank.
3. Remove the spark plug cap from the spark plug.
4. Remove the upper engine mounting plates.
5. Remove the six nuts and remove the cylinder head.
6. Remove the carburetor (Page 40), intake tube and reed valve assembly.
7. Remove the exhaust pipe joint.



Fig. 3-10

8. Remove the four nuts and remove the cylinder.



Fig. 3-11 (1) Cylinder (2) Nuts (four)

9. Put a clean cloth over the bore in the crankcase. Remove the piston pin clip, piston pin and piston.

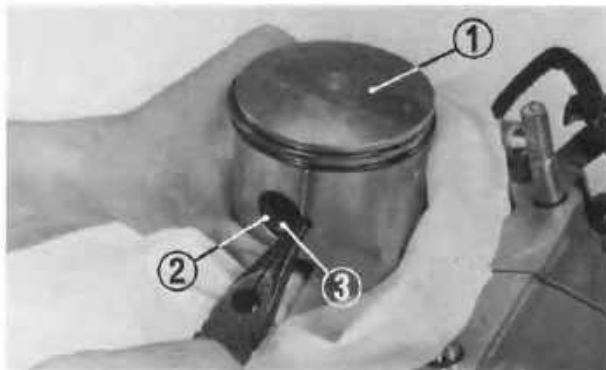

Fig. 3-12 (1) Piston (2) Piston pin clip (3) Piston pin

Inspection

1. Carbon deposits:
Remove carbon deposits from the combustion chamber, exhaust port and piston.
2. Measure the cylinder bore at 15–20 mm from the top of the cylinder. If the I.D. exceeds 70.05 mm (2.758 in), replace the cylinder.

CAUTION

Do not try to re bore the cylinder. Boring will make the cylinder unserviceable by removing the chrome plating.

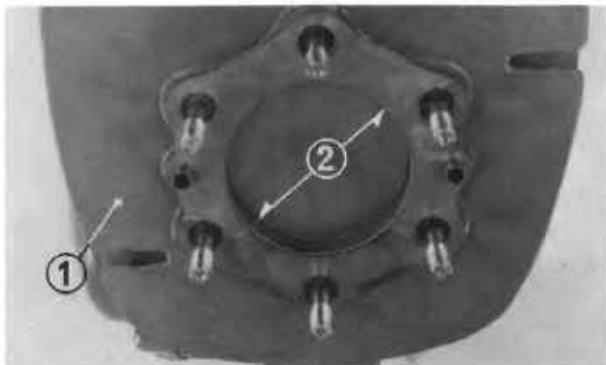

Fig. 3-13 (1) Cylinder (2) Cylinder bore

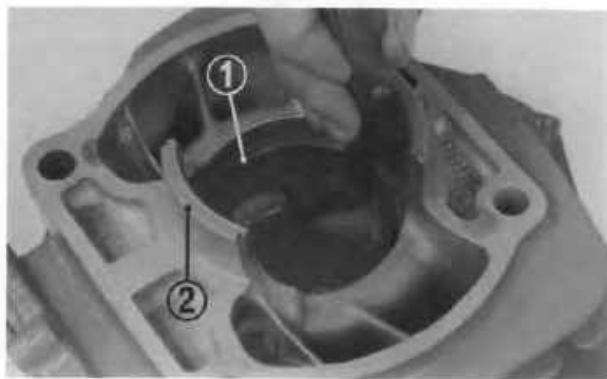

Fig. 3-14 (1) Piston ring (2) Cylinder

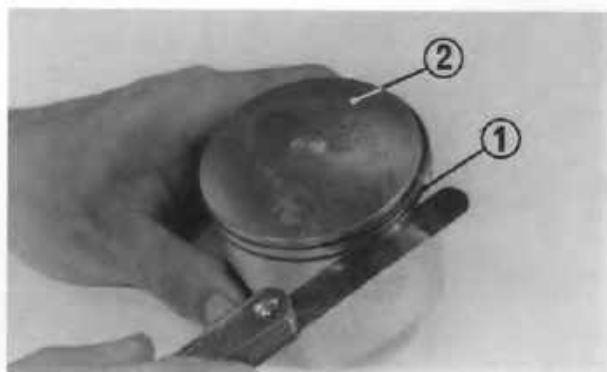

Fig. 3-15 (1) Piston (2) Piston ring

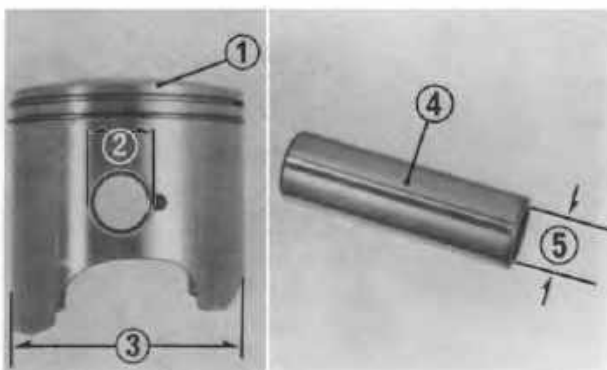

Fig. 3-16 (1) Piston (2) Piston pin bore
(3) Piston O.D. (4) Piston pin (5) Piston pin O.D.



Fig. 3-17 (1) Reed valve (2) Reed stoppers

3. Piston ring end gap:

Seat the piston rings in the cylinder, as shown and measure the ring end gap with a feeler gauge. If the gap exceeds **0.6 mm (0.024 in.)**, replace the rings.

4. Piston ring (second ring) groove side clearance:

Measure the side clearance with a feeler gauge. If the clearance exceeds the service limit, replace the ring. If the clearance is too great even with new rings, replace the piston and ring.

Service limit: 0.07 mm (0.0028 in.)

5. Measure the piston O.D. at 5-10 mm up from the bottom of the skirt and at right angle to the piston pin hole. If the O.D. is under the service limit, replace the piston with a new one.

Service limit: 69.800 mm (2.7480 in.)

6. Check the piston pin for wear and excessive discoloration; replace if necessary.

Piston pin O.D.:

Service limit: 17.980 mm (0.7079 in.)

7. Reed valves:

Check the reeds for damage or deformation.

CAUTION

Do not damage or distort the reed stoppers: Impaired engine performance will result if valve opening is altered.

Assembly

1. When installing new piston rings, put them in the ring grooves and turn the rings to check for smooth movement. The piston rings should be installed with their markings facing upward. Decarbonize the ring grooves if necessary.

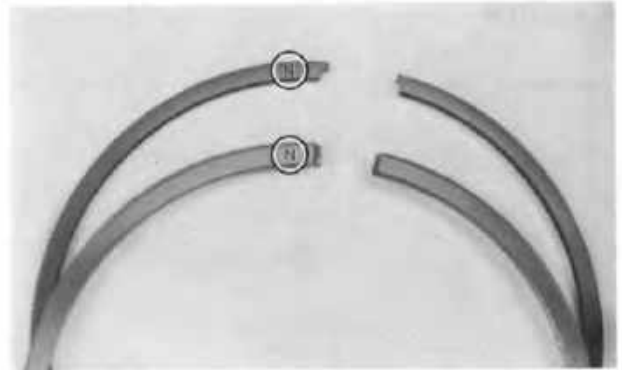

Fig. 3-18

When installing the top and second rings to the piston, install them in their correct positions.

- The top ring is a Keystone type and the free ring gap is 6.0–6.5 mm (0.24–0.26 in.)
- The second ring is a flat type and the free ring gap is 5.0–5.5 mm (0.20–0.22 in.)

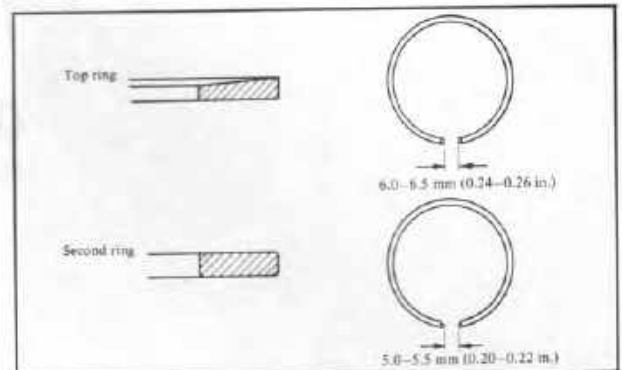

Fig. 3-19

2. Install the piston to the connecting rod with the “IN” mark on the piston head toward the rear of the engine.

NOTE:

Discard the used piston pin clip. Use a new clip.
Align the piston ring end gaps with the piston ring stoppers.



Fig. 3-20 (1) Piston ring stopper (2) Top ring (3) Second ring (4) Piston

3. Apply a thin coat of 2-stroke oil to the cylinder wall. Align the piston ring end gaps with the locating pins.
4. Slowly lower the cylinder over the piston with the intake side facing rearward. Take care not to catch the rings in a port, which could damage the rings or cylinder. Push the cylinder onto the crankcase and tighten the nuts.

Specified Torque: Cylinder nuts 3.8–4.8 kg-m (28–35 lb-ft)

CAUTION

Avoid damaging the piston rings during assembly.

5. Install the dowel pins, cylinder head gasket and cylinder head.

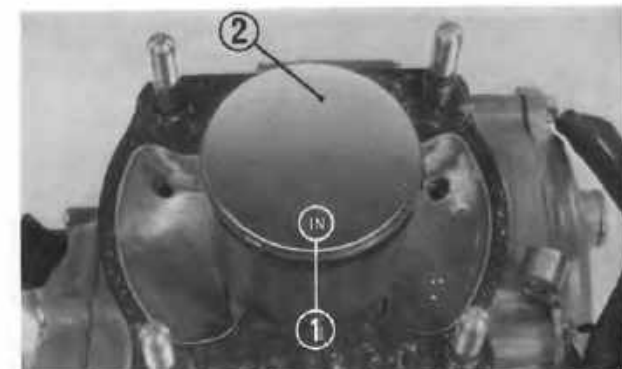

Fig. 3-21 (1) Index mark (2) Piston

4. CLUTCH

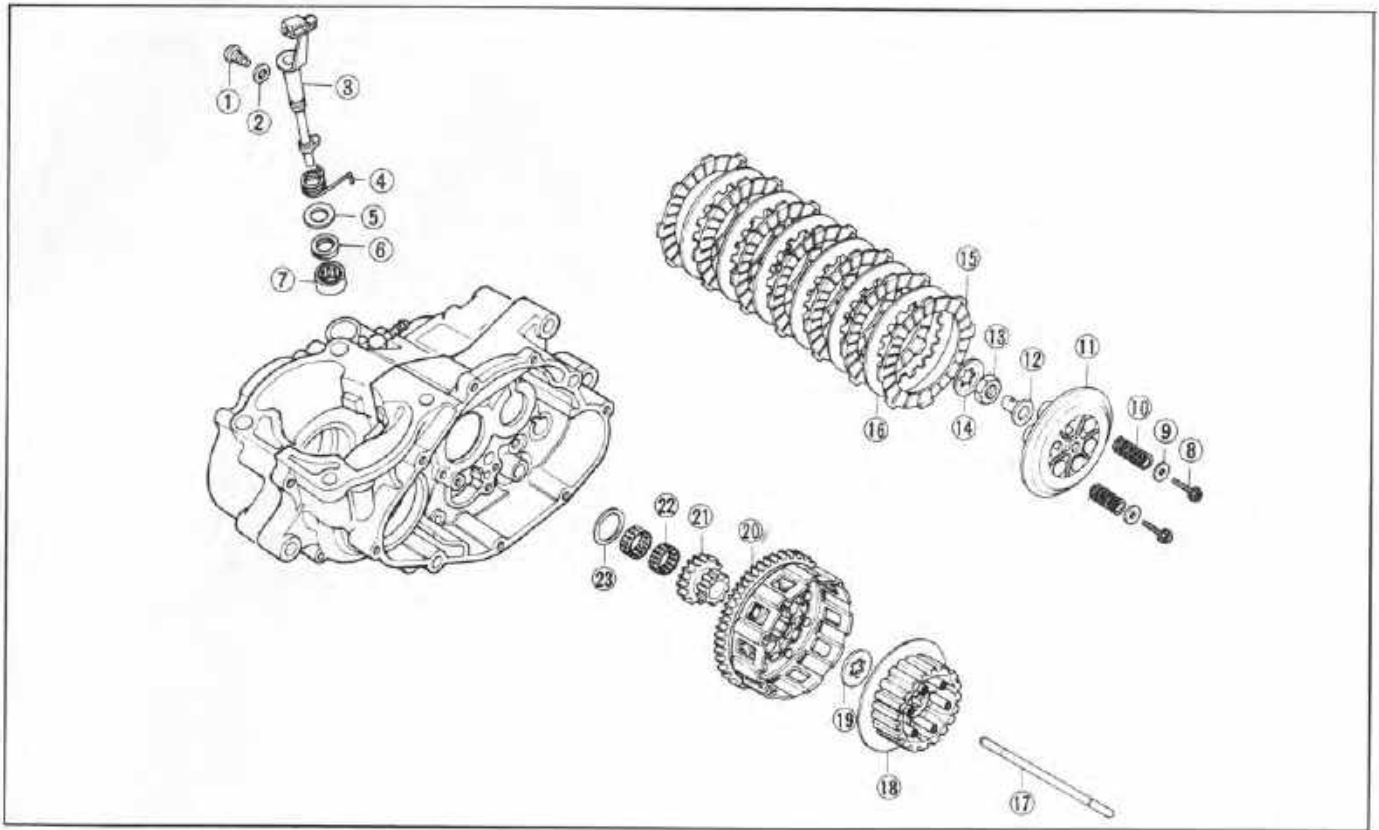

Fig. 3-22

- | | | | |
|-------------------------|----------------------------|--------------------------|----------------------------------|
| (1) Special bolt | (7) Needle bearing | (13) Clutch nut | (19) Splined washer |
| (2) Sealing washer | (8) Flange bolt (six) | (14) Splined lock washer | (20) Clutch outer |
| (3) Clutch lifter shaft | (9) Plain washer (six) | (15) Clutch disc (seven) | (21) Primary starter driven gear |
| (4) Lifter shaft spring | (10) Clutch spring (six) | (16) Clutch plate (six) | (22) Needle bearing |
| (5) Special washer | (11) Clutch pressure plate | (17) Clutch lifter rod | (23) Thrust washer |
| (6) Oil seal | (12) Clutch lifter | (18) Clutch center | |



Fig. 3-23

Disassembly

1. Drain the transmission oil from the crankcase.
2. Remove the left foot peg.
3. Remove the gearshift pedal.
4. Remove the kickstarter pedal.
5. Remove the nine left crankcase cover screws. Then remove the left crankcase cover.

7. Remove the six bolts and remove the clutch springs (six) and plain washers (six).
Remove the clutch pressure plate.

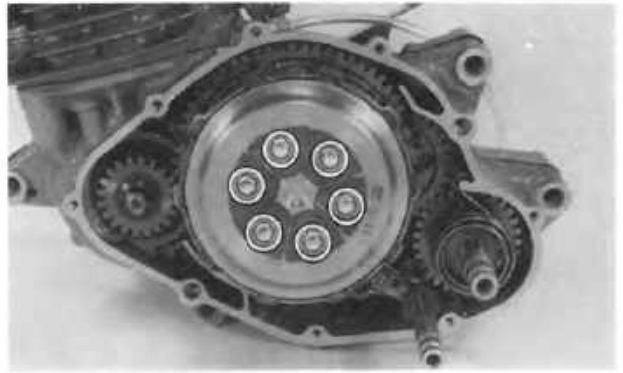

Fig. 3-24

8. Remove the clutch lifter and clutch lifter rod.

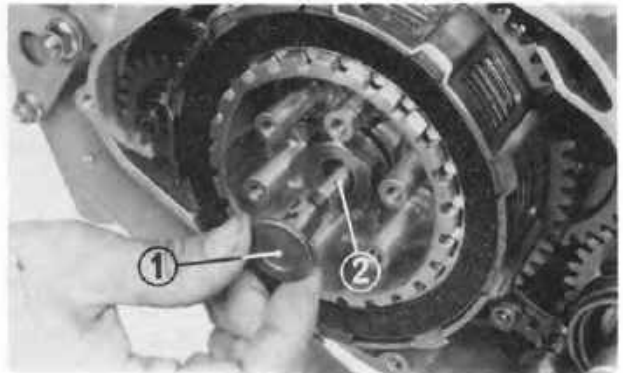
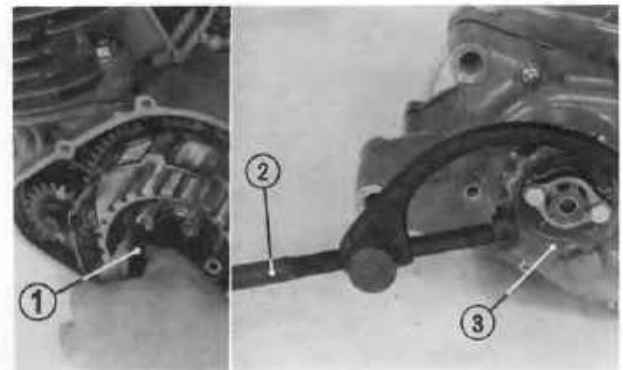

Fig. 3-25 (1) Clutch lifter (2) Clutch lifter rod

9. Remove the seven clutch friction discs and six clutch plates.
10. Straighten the tab of the lock washer.
Shift the transmission into gear. Hold the drive sprocket with the drive sprocket holder. Remove the clutch nut and clutch center.

Fig. 3-26 (1) Lock nut wrench (2) Universal holder
(3) Drive sprocket

11. Remove the splined washer, clutch outer, needle bearings and thrust washer.

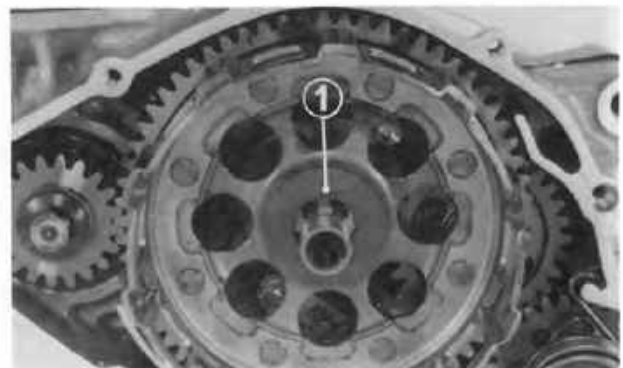

Fig. 3-27 (1) Splined washer



Fig. 3-28 (1) Clutch disc (2) Clutch center (3) Clutch outer

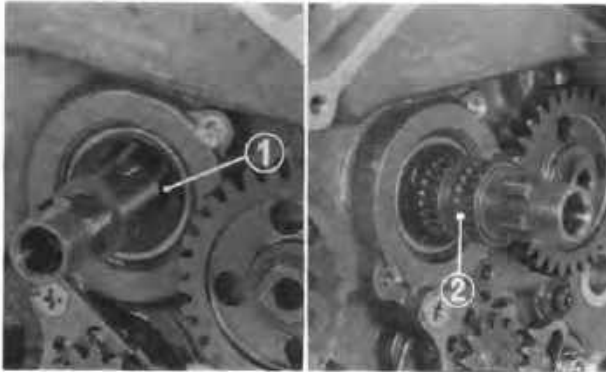

Fig. 3-29 (1) Thrust washer (2) Needle bearing

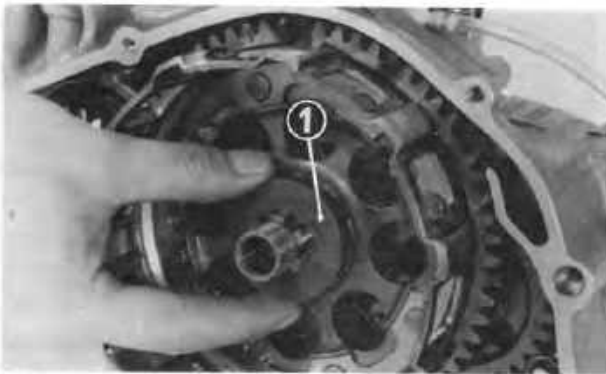

Fig. 3-30 (1) Splined washer

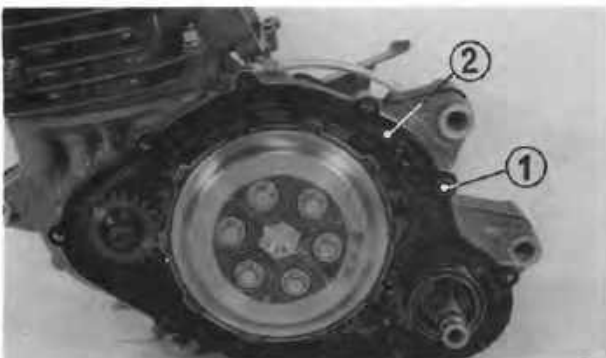

Fig. 3-31 (1) Dowel pin (2) Gasket

Inspection

1. Check the clutch friction discs for burning, wear or any other defects, and replace any damaged discs.
2. Check the clutch plates for face runout. Warped or damaged plates may cause the clutch to slip when engaged. Replace the plates if necessary.
3. Check the clutch springs for fatigue and replace them if necessary.
4. Check the clutch outer for stepped wear and replace it if necessary.

Assembly

1. Install the thrust washer and needle bearings to the main shaft.

2. Install the clutch outer. Install the splined washer to the main shaft and rotate the shaft until the washer meshes with the shaft.
3. Install the seven friction discs and six clutch plates on the clutch center (alternating the friction discs and clutch plates).

CAUTION

Before assembling, lubricate new clutch discs with transmission oil.

4. Install the lock washer and tighten the clutch nut, then bend the tab of the lock washer to lock the clutch nut.
5. Install the clutch lifter rod, clutch lifter, and clutch pressure plate.

Install the six springs and six washers and tighten the six flange bolts.

Specified torque:

Flange bolt 0.8–1.2 kg-m (5.8–8.7 lbs-ft)

6. Install the dowel pins and gasket. Install the left crankcase cover.
7. After assembling, fill the transmission with the recommended oil up to the correct level (page 8).

5. KICKSTARTER

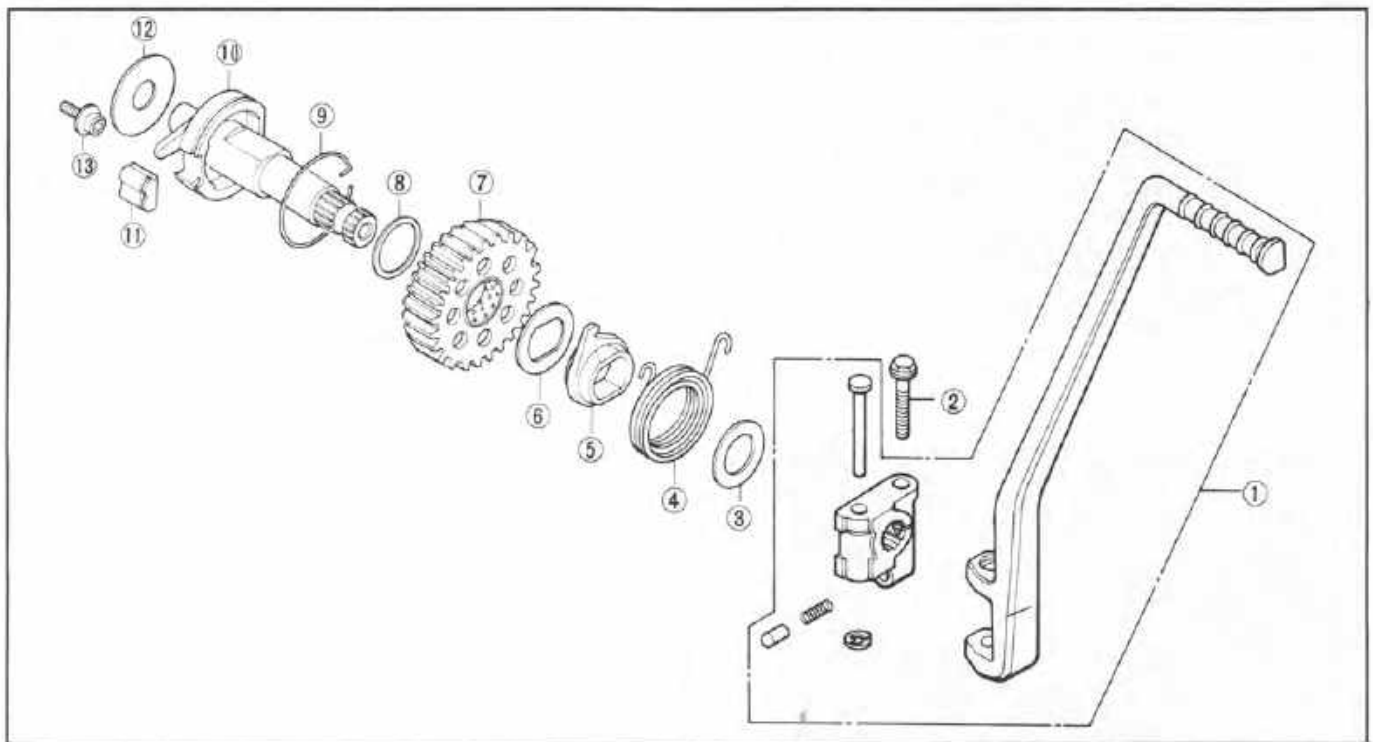

Fig. 3-32

- | | | |
|---------------------------------------|---------------------------------------|--------------------|
| (1) Kickstarter pedal | (6) Thrust washer (22 x 35 x 1.0 t) | (11) Starter pawls |
| (2) Bolt | (7) Starter pinion | (12) Thrust washer |
| (3) Thrust washer (18 x 32 x 2.0 t) | (8) Thrust washer (22 x 27 x 1.0 t) | (13) Stopper |
| (4) Starter return spring | (9) Starter pawl spring | |
| (5) Spring retainer | (10) Starter spindle | |

Disassembly

1. Drain the transmission oil from the crankcase.
2. Remove the left foot peg.
3. Remove the gearshift pedal.
4. Remove the kickstarter pedal.
5. Remove the left crankcase cover.
6. Take the return spring off and remove the kickstarter assembly.

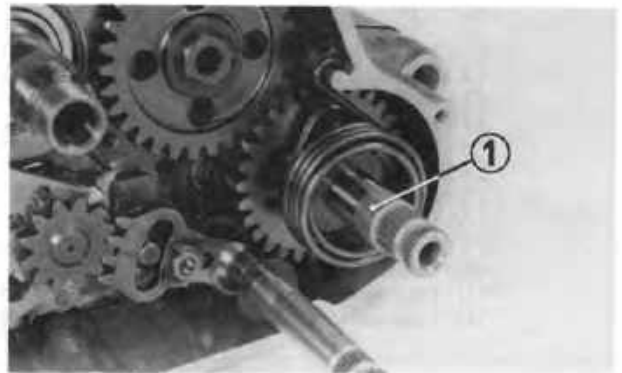

Fig. 3-33 (1) Kickstarter

Inspection

1. Check the ratchet pawl for damage and the pawl spring for fatigue.

Assembly

After assembling, fill the transmission with the recommended oil up to the correct level (page 8).



Fig. 3-34 (1) Oil filler cap

6. GEARSHIFT MECHANISM

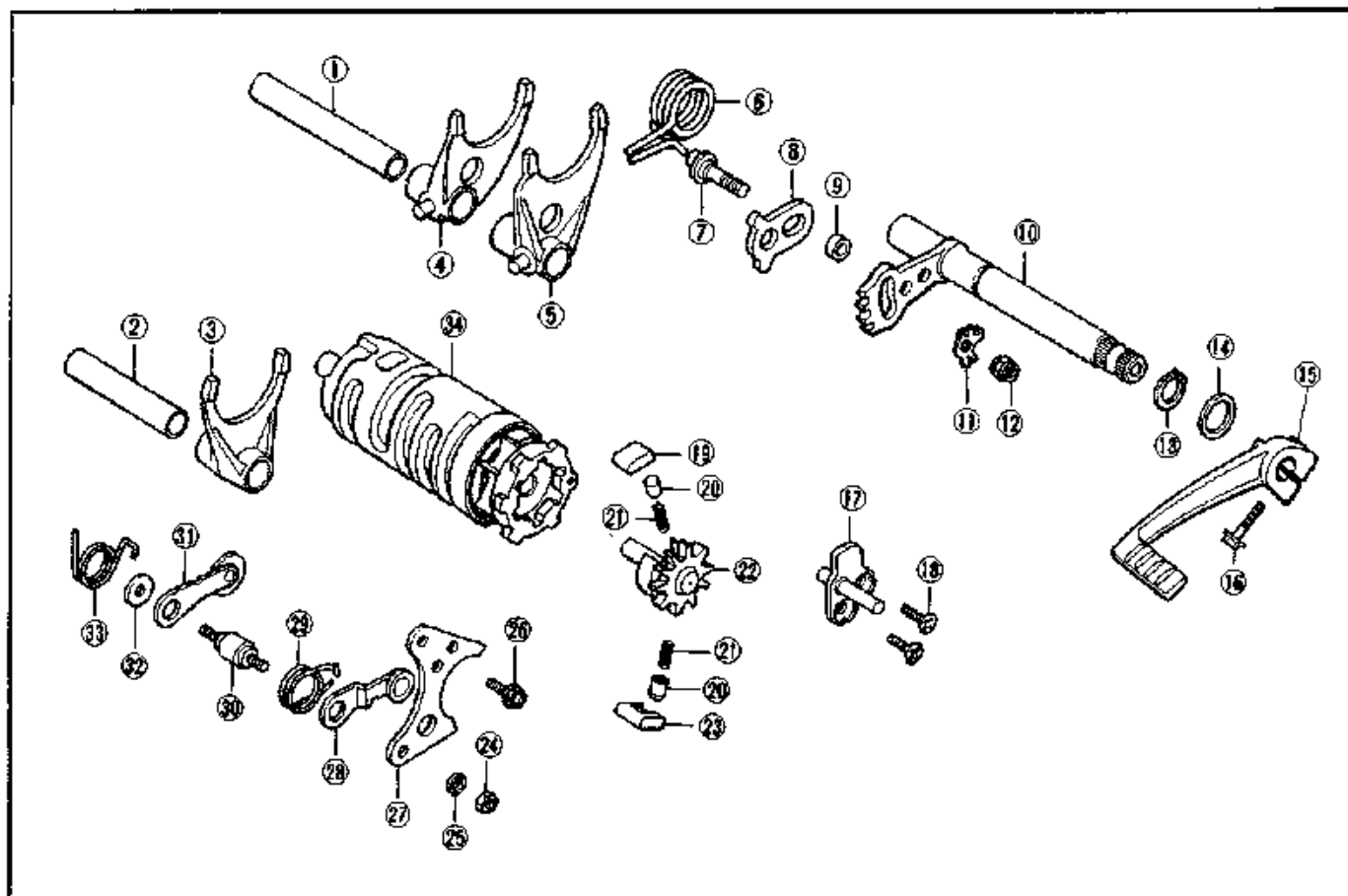

Fig. 3-35

- | | | |
|-----------------------------|---------------------------|---------------------------------|
| (1) Shift fork shaft A | (13) Circlip | (25) Spring washer |
| (2) Shift fork shaft B | (14) Thrust washer | (26) Bolt |
| (3) Center fork | (15) Gearshift pedal | (27) Guide plate |
| (4) Right fork | (16) Bolt | (28) Neutral stopper arm |
| (5) Left fork | (17) Shift return spring | (29) Neutral stopper arm spring |
| (6) Gearshift return spring | (18) Screw (two) | (30) Drum stopper bolt |
| (7) Adjusting bolt | (19) Ratchet pawl A | (31) Drum stopper arm |
| (8) Setting plate | (20) Pawl plunger (two) | (32) Plain washer |
| (9) Collar | (21) Plunger spring (two) | (33) Drum stopper arm spring |
| (10) Gearshift spindle | (22) Drum shifter | (34) Gearshift drum |
| (11) Lock washer | (23) Ratchet pawl B | |
| (12) Lock nut | (24) Nut | |

Disassembly

1. Remove the clutch (Section III-4).
2. Remove the gearshift spindle.



Fig. 3-36 (1) Gearshift spindle

3. Remove the nut and screw and remove the guide plate. Then remove the drum shifter while holding the two ratchet pawls.

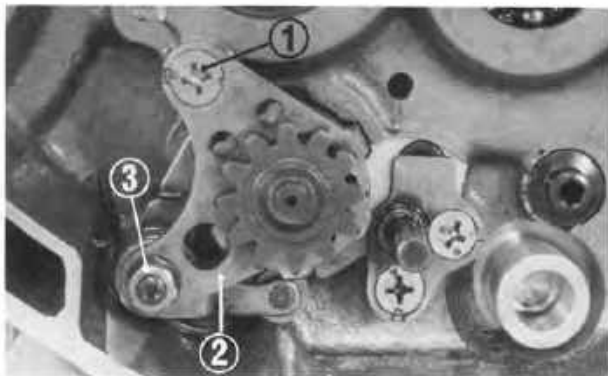

Fig. 3-37 (1) Screw (2) Guide plate (3) Nut

4. Remove the neutral stopper and return spring.

CAUTION

Do not try to remove the drum stopper arm bolt unless necessary.

Inspection

1. Inspect the stoppers arm and arm springs for damage.
2. Inspect the gearshift spring for damage.

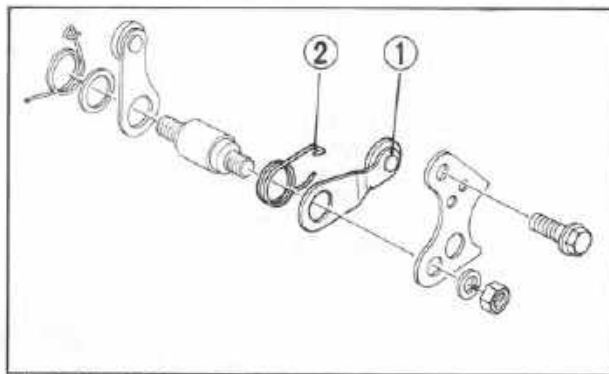
Fig. 3-38 (1) Neutral stopper arm
(2) Neutral stopper arm spring**Assembly**

1. Place the gearshift drum in the neutral position.
2. Install the drum stopper arm, neutral stopper arm and springs.

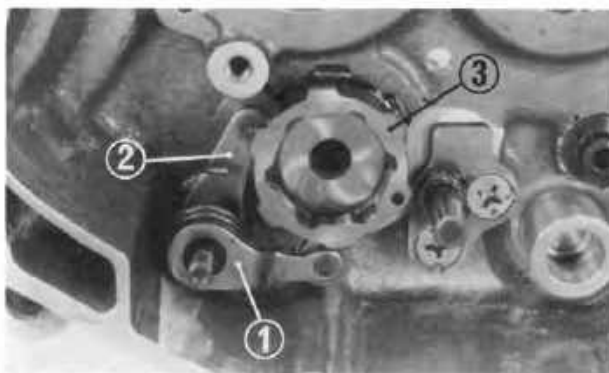
Fig. 3-39 (1) Neutral stopper arm
(2) Drum stopper arm
(3) Gearshift drum

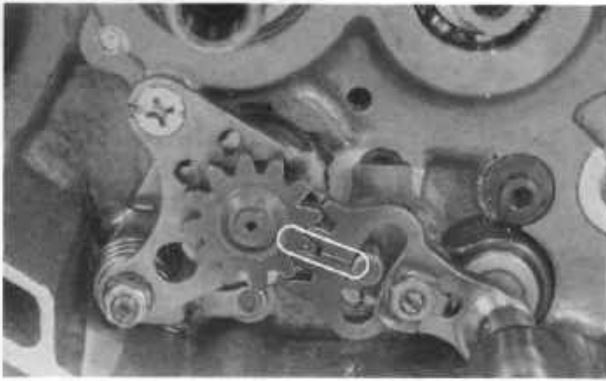

Fig. 3-40

3. Install the drum shifter and gearshift spindle by lifting the index mark on the spindle ratchet with the punch mark on the drum shifter tooth.

NOTE:

Ensure that the ratchet pawls are installed correctly.

4. To adjust, straighten the tab of the lock washer, loosen the lock nut and turn the adjusting bolt.

CAUTION

After adjusting, tighten the lock nut and bend the tab of the lock washer.

7. CRANKCASE AND TRANSMISSION

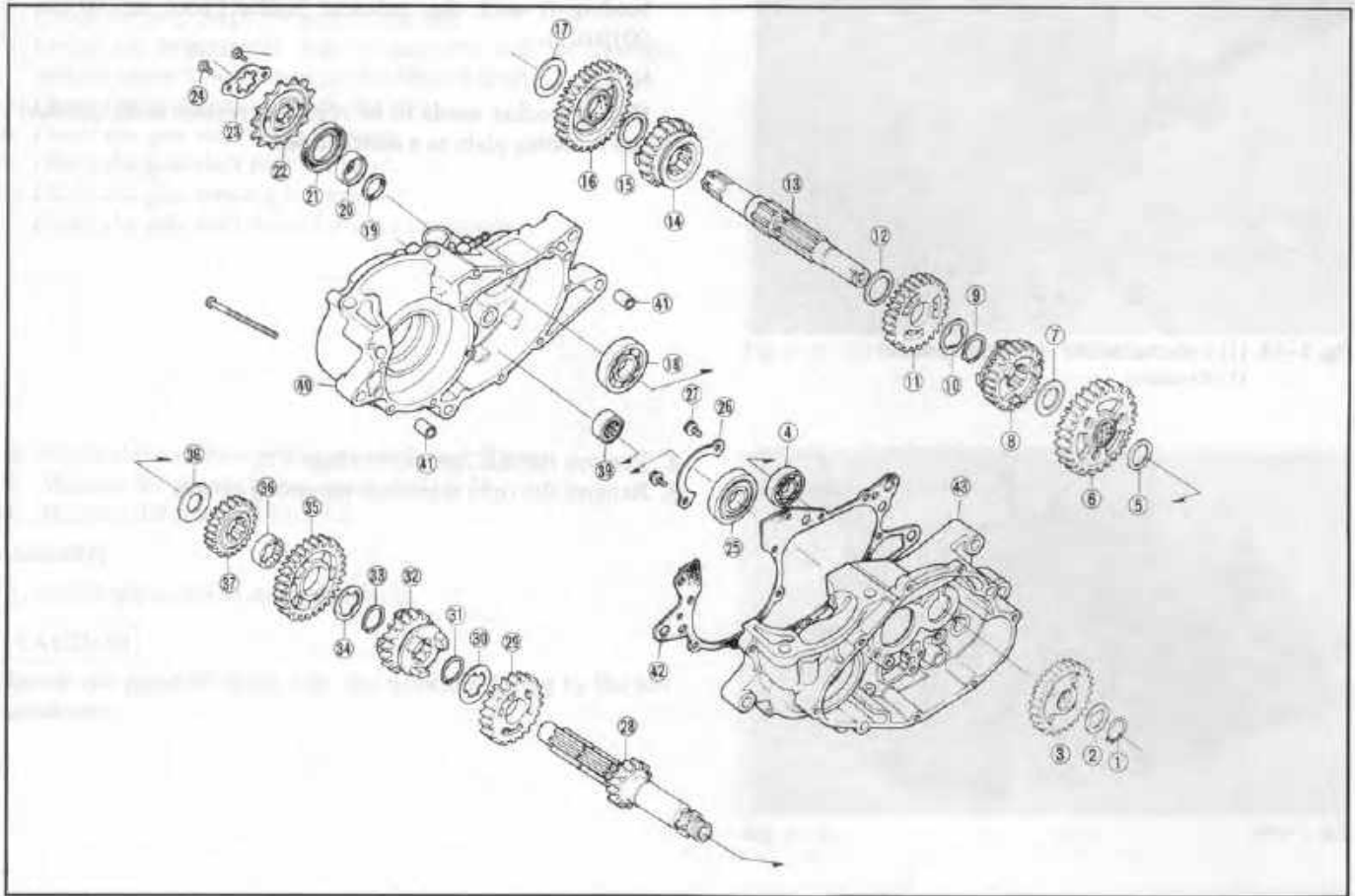

Fig. 3-41

- | | | |
|---------------------------------------|---------------------------------------|---------------------------------------|
| (1) Snap ring | (16) Countershaft second gear (35T) | (31) 25 mm snap ring |
| (2) Thrust washer (17 x 26 x 1.0 t) | (17) Thrust washer (22 x 34 x 1.0 t) | (32) Mainshaft third gear (25T) |
| (3) Starter idle gear | (18) Ball bearing | (33) 25 mm snap ring |
| (4) Ball bearing | (19) Oil seal | (34) Splined washer (25 x 32 x 1.6 t) |
| (5) Thrust washer (17 x 26 x 1.9 t) | (20) Oil seal guide | (35) Mainshaft fifth gear (31T) |
| (6) Countershaft low gear (38T) | (21) Oil seal | (36) Splined collar |
| (7) Thrust washer (20 x 32 x 1.0 t) | (22) Drive sprocket | (37) Mainshaft second gear (22T) |
| (8) Countershaft fourth gear (28T) | (23) Fixing plate | (38) Thrust washer |
| (9) 25 mm snap ring | (24) Bolt (two) | (39) Needle roller bearing |
| (10) Splined washer (25 x 32 x 1.6 t) | (25) Bearing | (40) Right crankcase |
| (11) Countershaft third gear (31T) | (26) Bearing set plate | (41) Dowel pin |
| (12) Thrust washer (25 x 30 x 1.0 t) | (27) Bolt (two) | (42) Crankcase gasket |
| (13) Countershaft | (28) Mainshaft fourth gear (28T) | (43) Left crankcase |
| (14) Countershaft fifth gear (26T) | (29) Mainshaft | |
| (15) Thrust washer (25 x 34 x 1.0 t) | (30) Splined washer (25 x 32 x 1.6 t) | |

Disassembly

1. Remove the engine (Section III-2).
2. Remove the cylinder head, cylinder and piston (Section III-3).
3. Remove the clutch (Section III-4).
4. Remove the kickstarter (Section III-5).
5. Remove the gearshift spindle and neutral stopper.
6. Remove the snap ring and remove the starter idle gear.

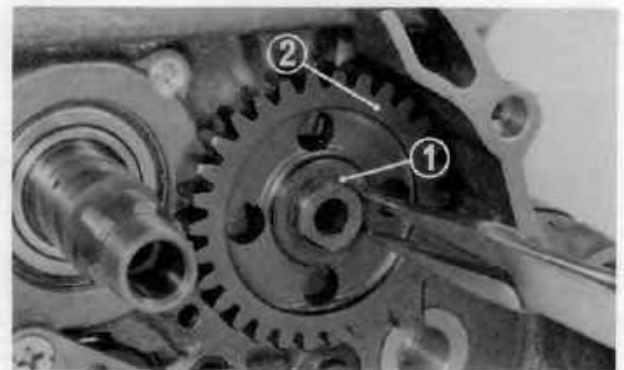

Fig. 3-42 (1) Snap ring (2) Starter idle gear

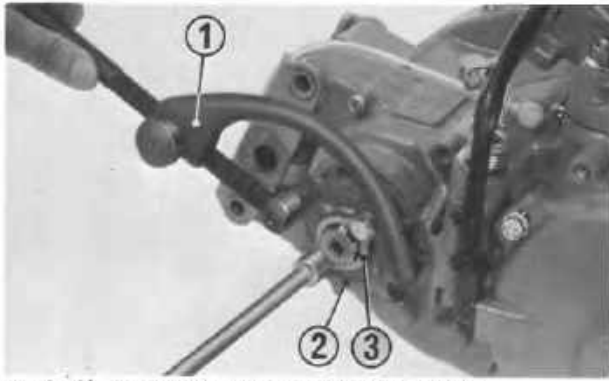

Fig. 3-43 (1) Universal holder (2) Drive sprocket
(3) Retaining

7. Remove the chain cover and remove the drive sprocket by holding it with the universal holder (Tool no. 07725-0010101).

NOTE:

If the sprocket needs to be replaced, replace both sprocket and retaining plate as a matched set.

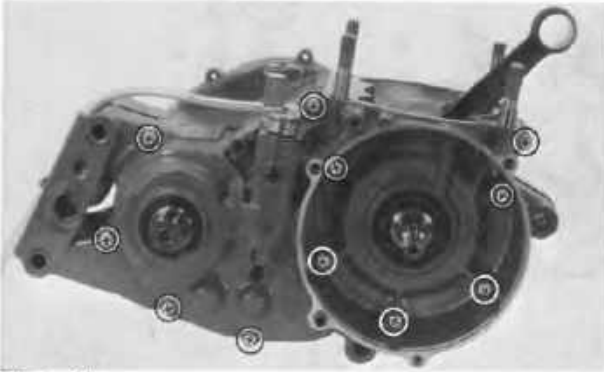

Fig. 3-44

8. Remove the A.C. generator (Page 57).
9. Remove the right crankcase mounting screws.

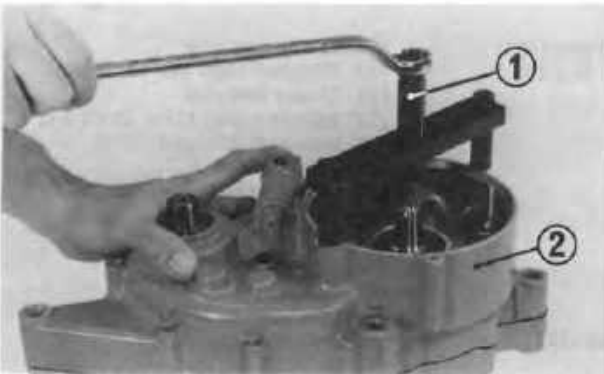

Fig. 3-45 (1) Crankcase disassembly tool (2) Right crankcase

10. Bolt the crankcase disassembly tool (Tool no. 07937-4300000) to the right crankcase as shown in Fig. 3-45. Turn the screw of the tool against the end of the crankshaft periodically tapping the end of the mainshaft to ensure the crankcase halves separate equally at the front and rear.

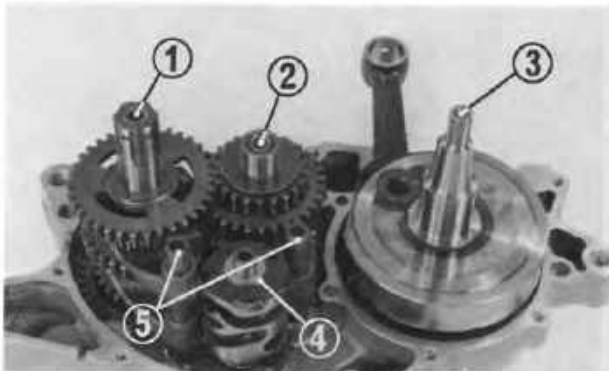

Fig. 3-46 (1) Countershaft (2) Mainshaft (3) Crankshaft
(4) Shift drum (5) Shift fork guide shaft

11. Remove the two shift fork shafts, three shift forks and gearshift drum.
12. Remove the mainshaft and countershaft gears.

Inspection

1. Check the gear teeth for wear or damage.
2. Check the engagement dogs of gears for wear or damage and for smooth movement on the splined shaft.
3. Check the gear and shift fork for play.
4. Check the gear shift forks for wear.
5. Check the gear shift fork for bend.
6. Check the gear bushing for wear.
7. Check the gear shift drum for wear or damage.

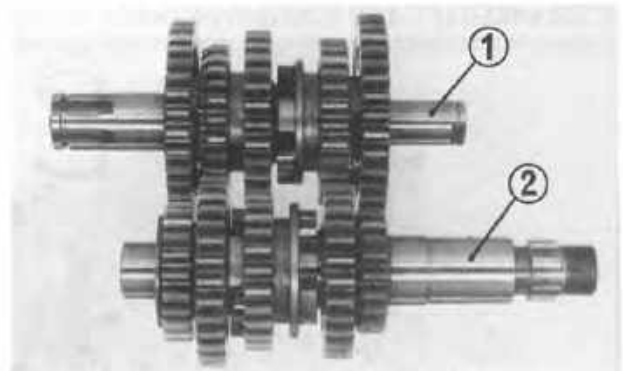

Fig. 3-47 (1) Countershaft (2) Mainshaft

8. Check the condition of the gearshift fork finger.
9. Measure the gearshift fork guide shaft O.D.
10. Measure the gearshift fork I.D.

Assembly

1. Install the gearshift drum and forks.

CAUTION

Install the gearshift forks with the markings facing to the left crankcase.

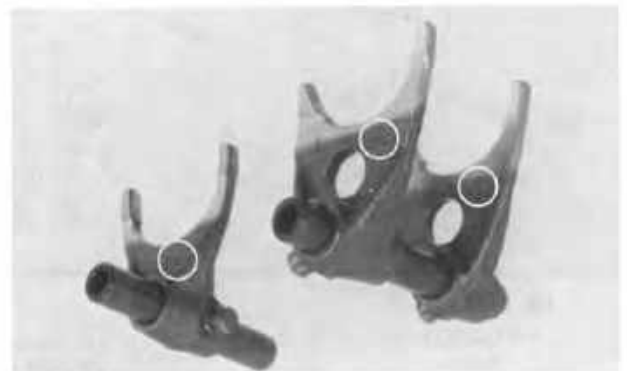

Fig. 3-48

2. When assembling the left and right crankcases, thoroughly clean the crankshaft chamber first.
3. When installing the mainshaft and countershaft, apply a coat of transmission oil to the bearing attaching surfaces. Also fill the shafts with oil.
4. When installing the mainshaft spline collar to the mainshaft, align the oil holes.

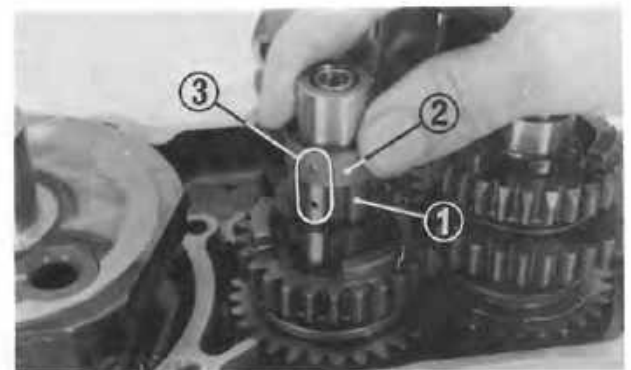

Fig. 3-49 (1) Countershaft (2) Splined collar (3) Holes

5. Fill the cavity between the double lips of the oil seal with gasoline resistant grease. Check the lips for burrs.

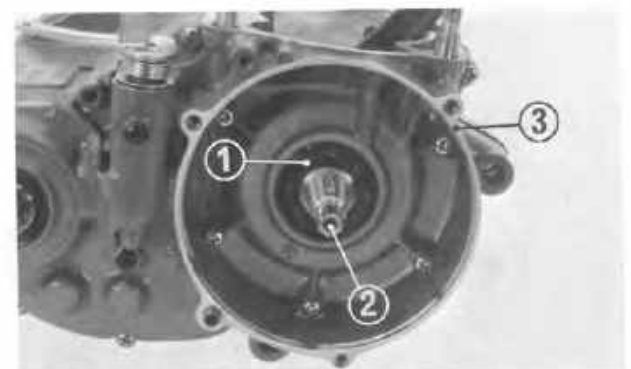

Fig. 3-50 (1) Oil seal (2) Countershaft (3) Right crankcase

8. CRANKSHAFT AND CONNECTING ROD

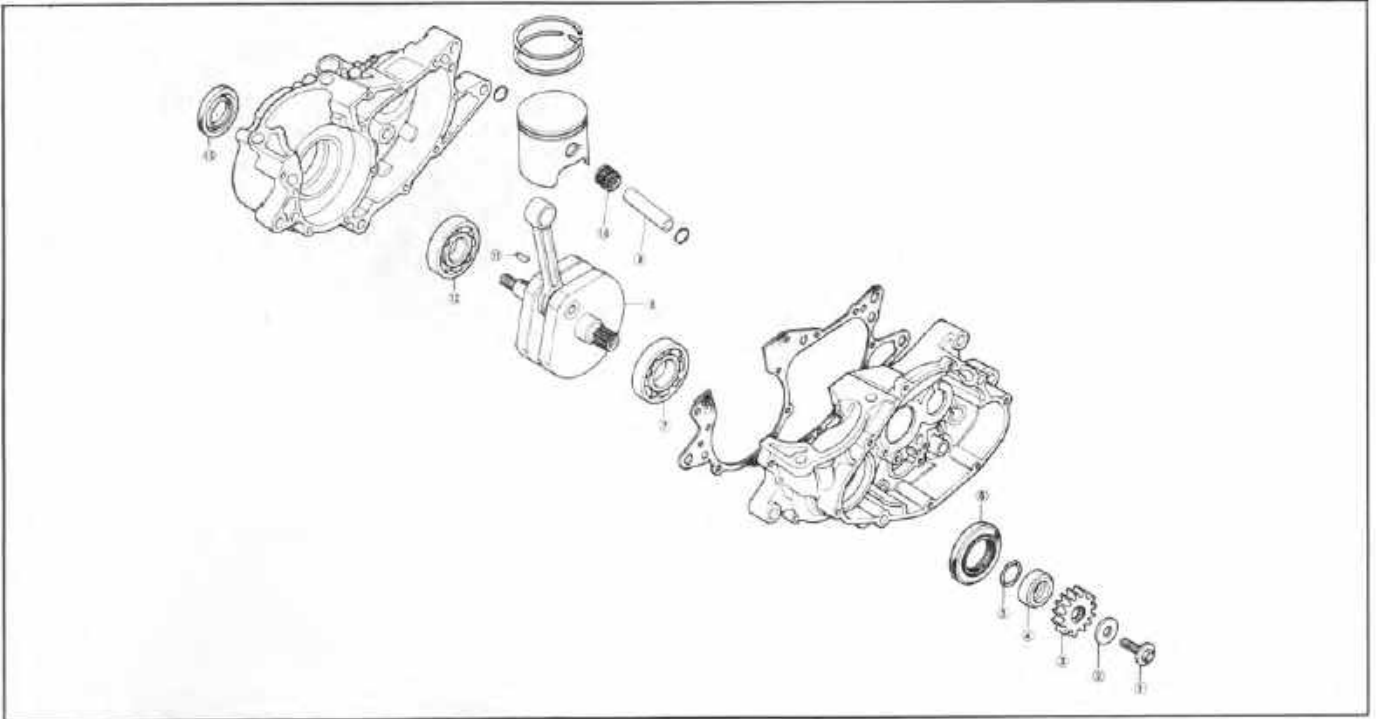

Fig. 3-51

- | | | |
|------------------------|----------------|---------------------------------------|
| (1) Special bolt | (5) O-ring | (9) Piston pin |
| (2) Washer | (6) Oil seal | (10) Connecting rod small end bearing |
| (3) Primary drive gear | (7) Bearing | (11) Woodruff key |
| (4) Drive gear collar | (8) Crankshaft | (12) Bearing |
| | | (13) Oil seal |

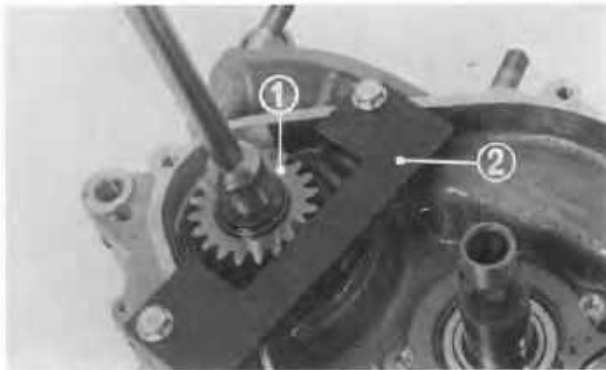

Fig. 3-52 (1) Drive gear (2) Drive gear holder

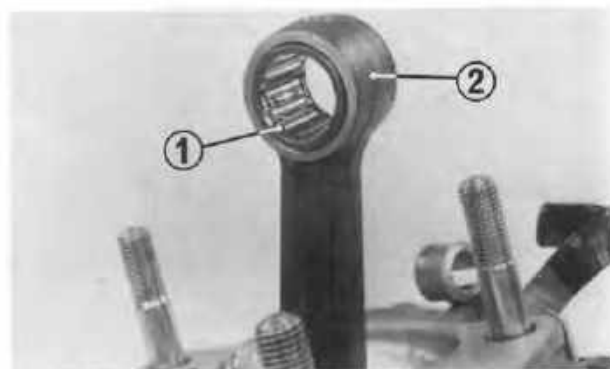

Fig. 3-53 (1) Small end bearing (2) Connecting rod

Disassembly

1. Disassemble the crankcase (Pages 38, 39).

NOTE:

Before disassembling the crankcase, remove the primary drive gear by using the drive holder (Tool no. 07924-4300000).

2. Remove the crankshaft assembly from the crankcase.

Inspection

Before disassembling, hold both ends of the crankshaft and check for looseness. If the crankshaft rattles, check to see if the rattle is caused by loose bearings or excessive clearance between the crankcase and bearing outer races.

9. CARBURETOR

Fig. 3-54

- (1) Rubber cap
- (2) Top set
- (3) Throttle valve set
- (4) Jet needle set
- (5) Starter valve set
- (6) Screw set
- (7) Air vent tube
- (8) Float valve set
- (9) Slow jet
- (10) Needle jet set
- (11) Main jet holder
- (12) Main jet
- (13) Float set
- (14) Float chamber set
- (15) Over flow tube

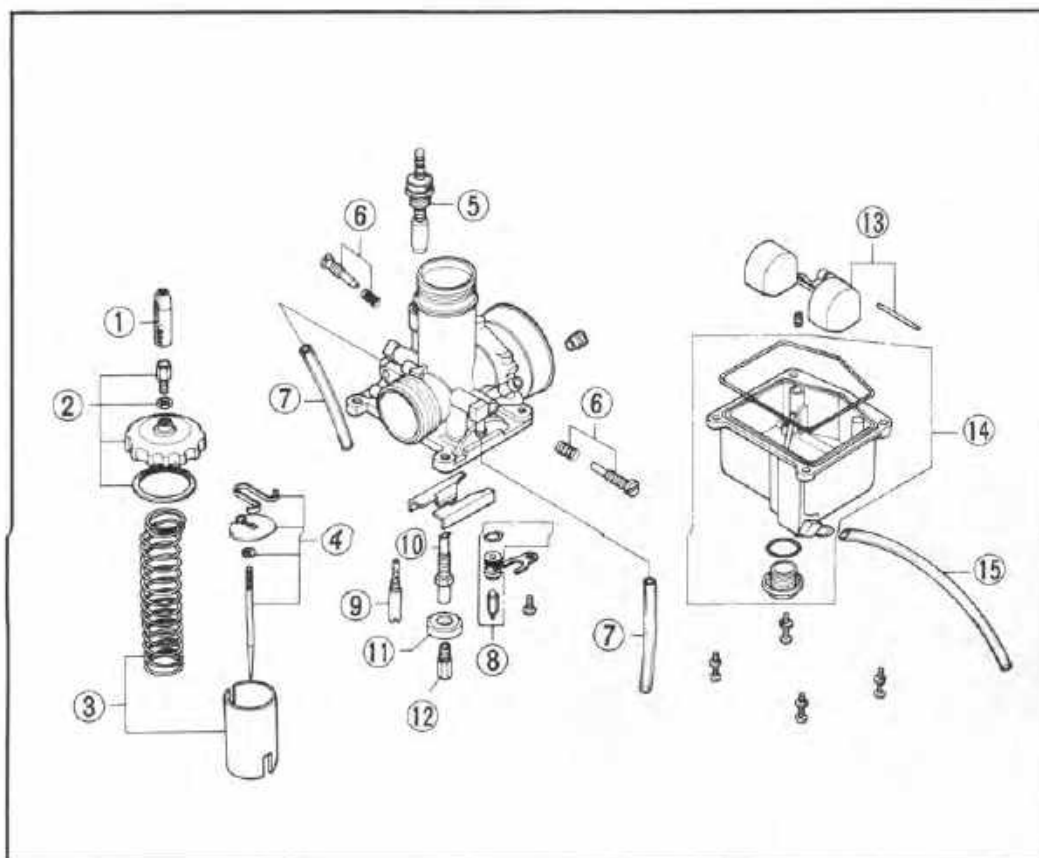

Construction

1. Starting circuit

When the starter valve (1) is opened, fuel is metered by the starter jet (2) and is mixed with air from the passage (3). Then, the mixture is drawn into the cylinder through hole (4).

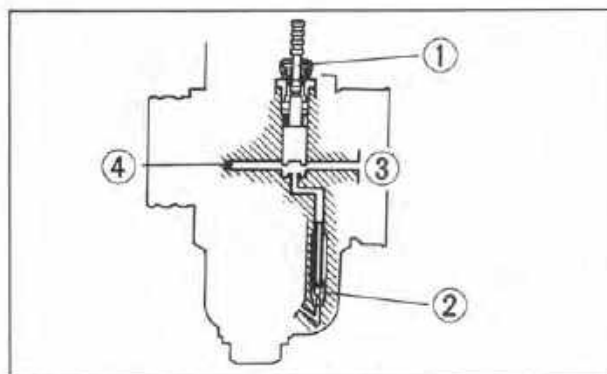

Fig. 3-55 (1) Starter valve (2) Starter jet

2. Slow circuit

Fuel is metered by the slow jet (5) and is mixed with air from the slow air passage which is metered by the air screw (6). Then, the mixture enters the venturi through the bypass (7) and pilot outlet (8).

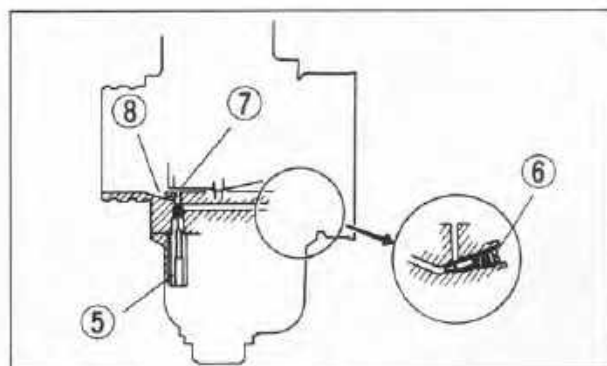

Fig. 3-56 (5) Slow jet (6) Air screw (7) Bypass (8) Pilot outlet

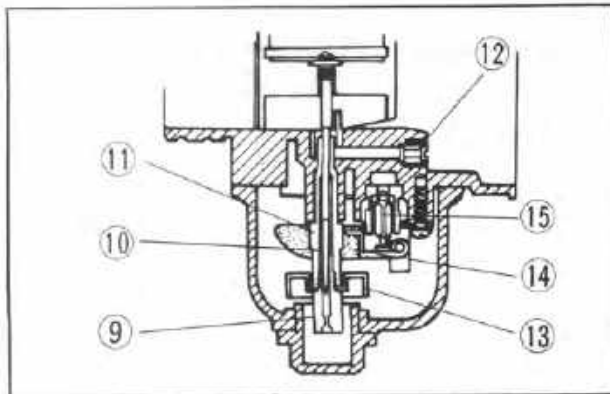

Fig. 3-57 (9) Main jet (12) Air jet (15) Float valve
(10) Jet needle (13) Jet holder
(11) Needle jet (14) Float



Fig. 3-58 (1) Intake tube band
(2) Connecting tube band

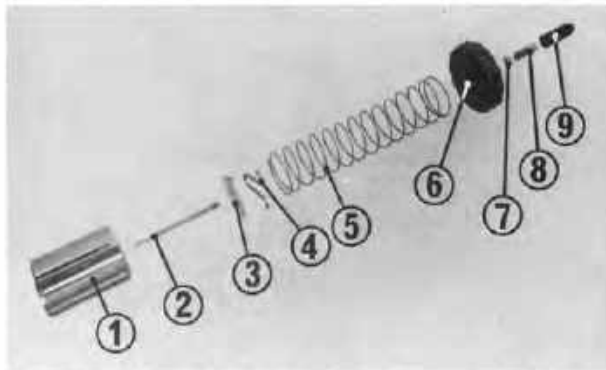

Fig. 3-59 (1) Throttle valve (5) Spring (9) Rubber cap
(2) Jet needle (6) Carburetor top
(3) Clip plate (7) Lock nut
(4) Clip (8) Adjuster



Fig. 3-60 (1) Air screw

3. Main circuit

Fuel metered by the main jet (9) flows through the passage between the jet needle (10) and needle jet (11) and is then mixed with air from the air jet (12). Then the mixture enters the venturi from the nozzle tip. The main jet holder (13) and the main jet (9) are secured together.

4. Float chamber

The float chamber maintains a constant fuel level. A spring built into the float valve (15) aids the valve in maintaining a seated position at the correct fuel level and helps prevent wear of the float valve and seat.

5. Baffle plate

The baffle plate installed in the float chamber inhibits changes in the fuel level caused by vibration.

Disassembly

1. Loosen the connecting tube band.
2. Loosen the intake tube band.
3. Remove the carburetor.

4. Remove the carburetor top, and remove the spring and throttle valve.

Inspection

1. Slow jet

The slow jet regulates the fuel flow in the slow circuit.

2. Air screw

The air screw regulates the flow of air in the slow circuit. Turning the air screw clockwise will make the mixture rich and turning it counterclockwise will make the mixture lean.

To adjust, warm up the engine and turn the air screw counterclockwise 1-1/2 turn from a fully closed position so that the engine idles smoothly. Open the throttle slightly and ensure that the engine revs up smoothly:

3. Throttle valve cutaway

The throttle valve cutaway regulates the flow of air at a throttle opening of 1/8-1/4. The higher the value of the marking, the leaner the mixture.

Road-test the motorcycle with 1/4 throttle. Check the spark plug if any roughness is felt. If the plug is wet, change the throttle valve for one with a larger number and if overheated, use a throttle valve with a smaller number.

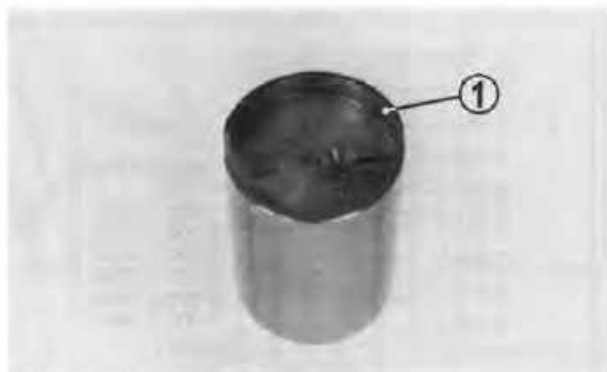

Fig. 3-61 (1) Throttle valve

4. Jet needle

The jet needle regulates the flow of fuel at throttle openings of 1/4-1/2. The straight part of the needle regulates fuel flows at low throttle opening, and the tapered part regulates fuel flow at mid-throttle.

Five grooves are cut into the needle head to allow for an adjustment of the needle. If throttle response is poor or if the engine will not maintain constant rpm, change the position of the needle. Before adjusting, set the main jet.

Example:

If the engine is running erratically with the jet needle set at the 3rd groove position, change to the 4th groove position. If the motorcycle jerks when accelerated or when running at a certain speed, change to a lower-numbered groove position.

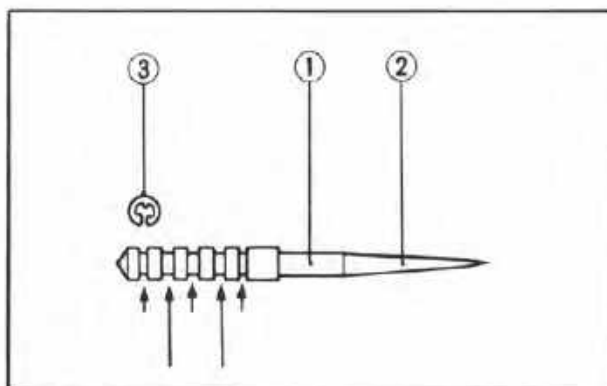

Fig. 3-62 (1) Straight (2) Tapered (3) Clip

5. Main jet

The main jet operates at 1/2 to full throttle and is important in regulating the flow of fuel from 3/4 to full throttle.

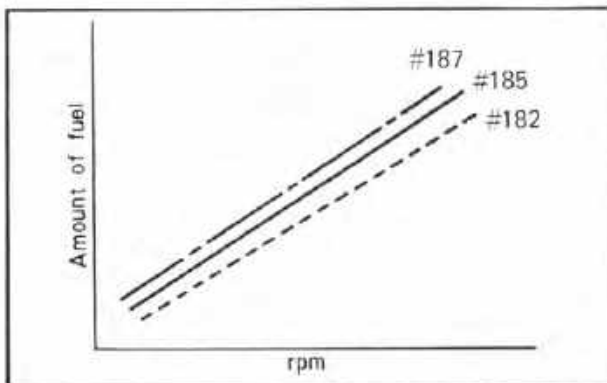

Fig. 3-63

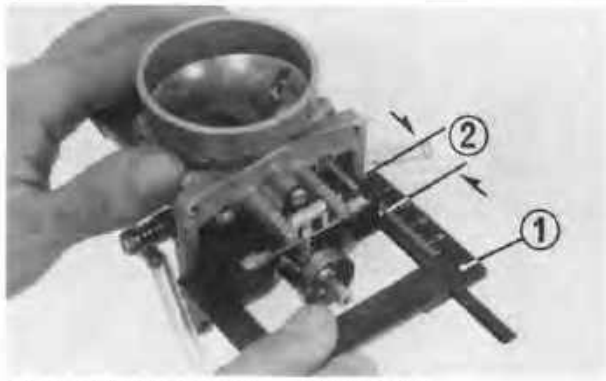

Fig. 3-64 (1) Float gauge (2) Float level

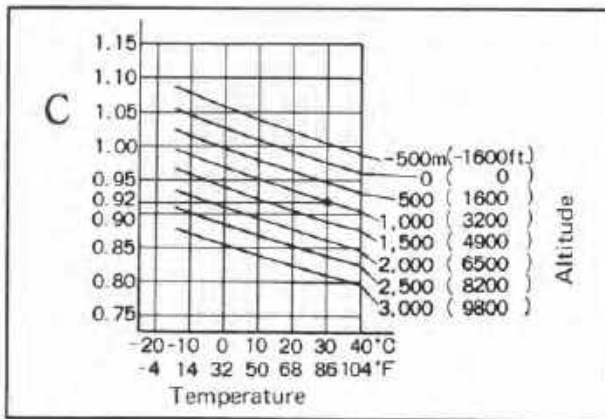
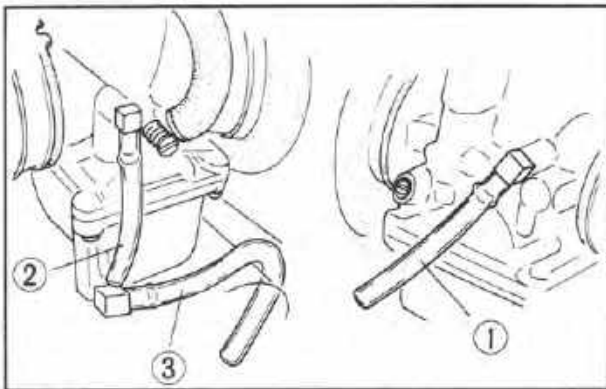

Fig. 3-65

Fig. 3-66 (1) Right carburetor breather tube
(2) Left carburetor breather tube
(3) Carburetor overflow tube

Carburetor Setting Table (STD)

Setting No.	PE01A
Main jet	#185
Air jet	#200
Slow jet	# 60
Throttle valve	# 2.5
Jet needle setting	Third groove
Jet needle	28A
Air screw opening	1-1/2 turn

6. Float level

Hold the carburetor with its main bore in a vertical position, so the float arm tang will just close the float valve, without compressing the spring loaded plunger in the end of the valve. Measure float height with a float level gauge. Float height (distance between the carburetor body and the opposite edge of the float) should be 19 mm (0.75 in.) when the float valve just closes.

If adjustment is needed, carefully bend the float arm tang toward or away from the float valve until the specified float height is obtained. Replace any damaged or leaking float.

7. Temperature and altitude correction factor

The carburetor should be adjusted for changes in temperature and altitude. Determine the needle and air screw settings and main jet size by correction factor C in the table below. Select the correct factor to meet riding conditions.

- Main jet
Specified main jet no. x C = Main jet to be used
- Jet needle
Specified jet needle groove no. + Rating of C = Groove no. to be used.

C	1.20 min.	1.20 1.05	1.05 0.95	0.95 0.80	0.80 max.
Rating	+2	+1	—	-1	-2

- (+) Raise the needle.
- (-) Lower the needle.

- Air screw
Specified Number of Turns + Rating of C = Turning no. to be used.

C	1.20 min.	1.20 1.05	1.05 0.95	0.95 0.80	0.80 max.
Rating	-1	-1/2	—	+1/2	+1

- (+) Increase the number of turns

For example:

At a temperature of 30°C (86°F) and an altitude of 1,000 m (3,200 ft.), carburetor recommendations are as follows:

- Main jet
185 x 0.92 = 170.2 • #170
- Jet needle
3 - 1 = 2 • 2nd groove
- Air screw opening
1-1/2 + 1/2 = 2 • 2 turns open

NOTE:

Connect each breather tube and overflow tube as shown in Fig. 3-66.

10. AIR CLEANER

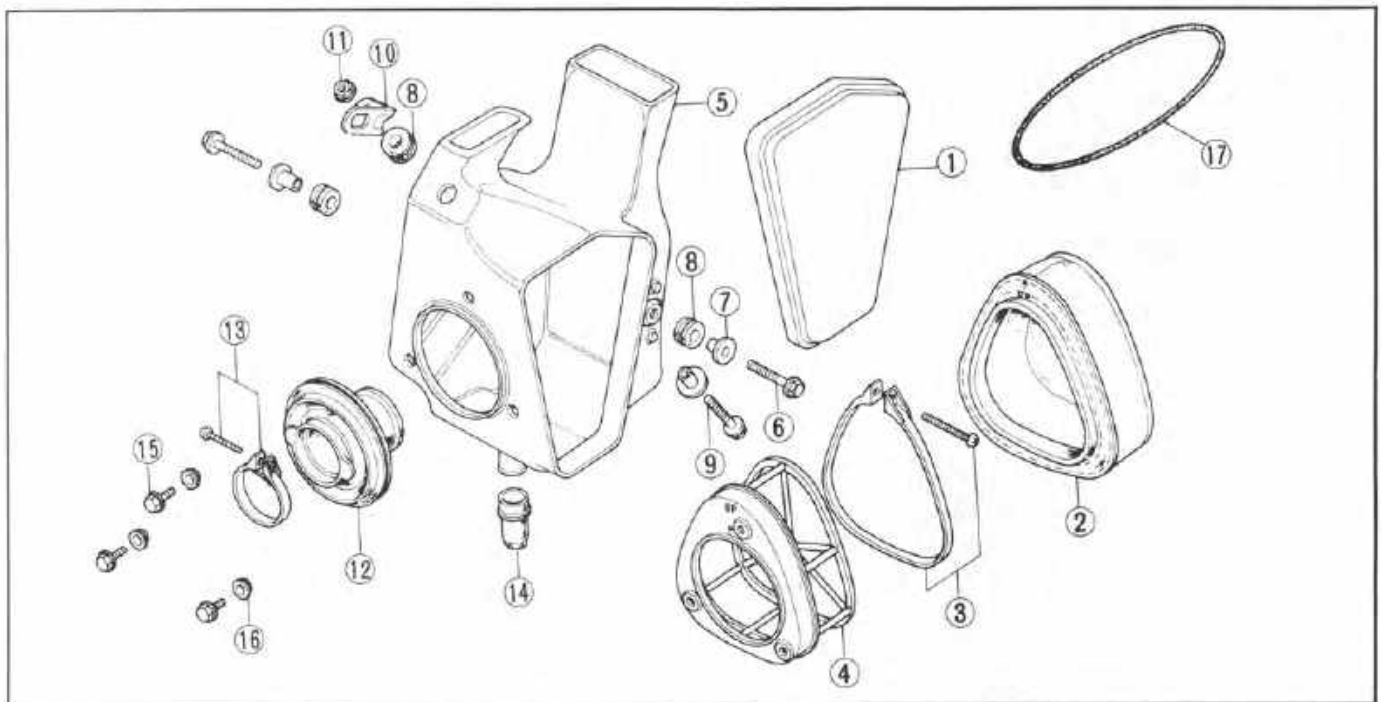

Fig. 3-67

- | | | | |
|---------------------------|-------------------------------|---------------------------|-------------------|
| (1) Air cleaner cover | (6) Bolt (two) | (11) Hex. nut | (17) Rubber Strap |
| (2) Air cleaner element | (7) Collar (three) | (12) Connecting tube | |
| (3) Element band | (8) Air cleaner case rubber | (13) Connecting tube band | |
| (4) Element holder | (9) Bolt | (14) Breather cap | |
| (5) Air cleaner case | (10) Air cleaner case holder | (15) Bolt (three) | |
| | | (16) Collar (three) | |

Disassembly

1. Remove the engine (Section III-2).
2. Remove the air cleaner case with the cleaner element.
3. Remove the air cleaner cover.
4. Remove the three bolts and remove the element holder and element.

Inspection

Check the air cleaner element for damage.



Fig. 3-68 (1) Air cleaner case

Assembly

1. Install the intake pipe with the marking "UP" facing upward.

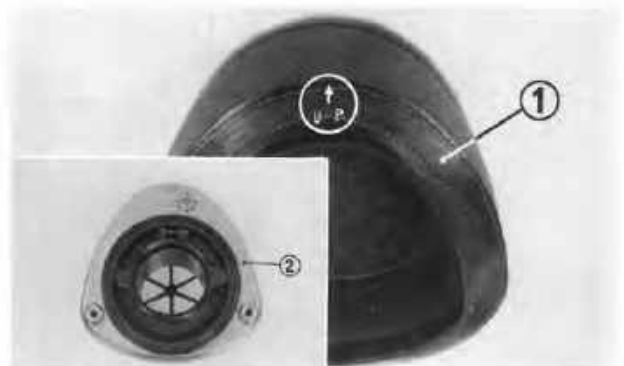
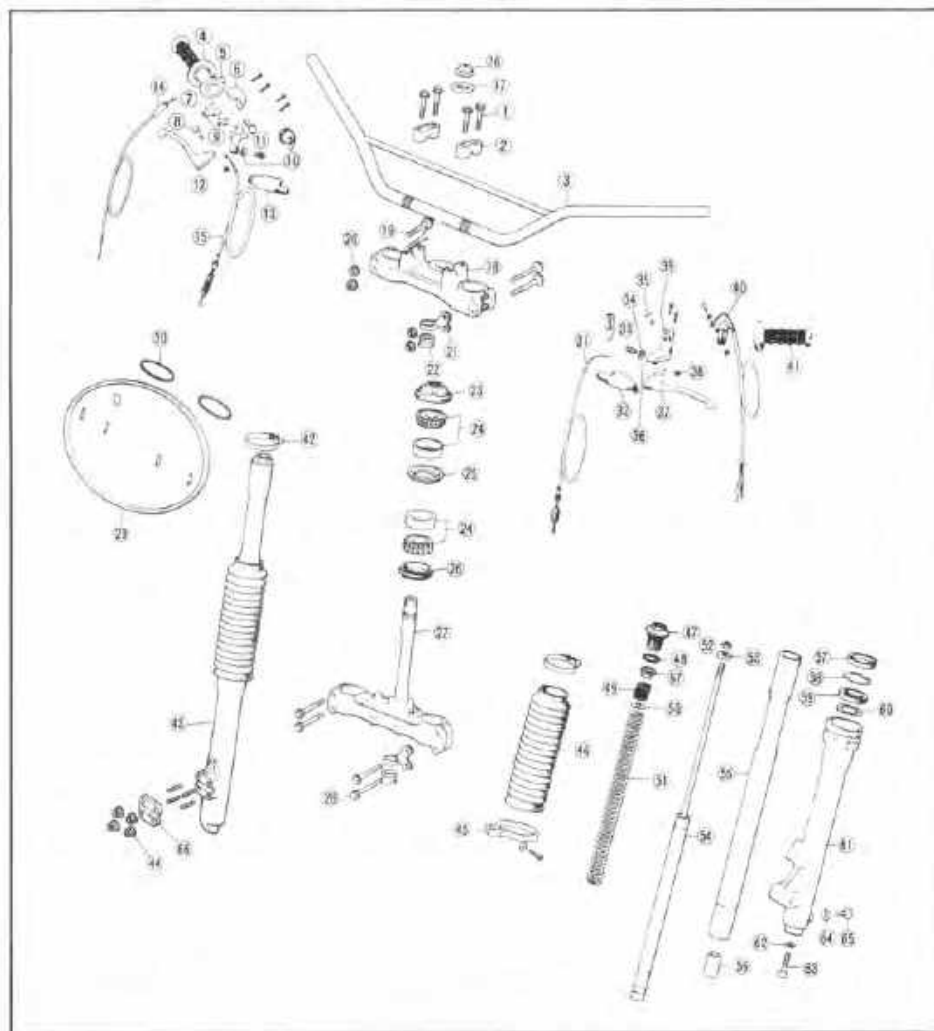

Fig. 3-69 (1) Air cleaner element
(2) Element holder

1. HANDLEBAR AND FRONT SUSPENSION



- (19) Flange bolt (four)
- (20) Flange nut (four)
- (21) Brake cable guide
- (22) Cable guide inner
- (23) Steering head bearing adjusting nut
- (24) Taper roller bearing (two)
- (25) Grease plate
- (26) Dust seal
- (27) Steering stem
- (28) Flange bolt (four)
- (29) Front number plate
- (30) Band (two)
- (31) Clutch cable
- (32) Clutch lever cover
- (33) Clutch upper adjuster
- (34) Lock nut
- (35) Clutch lever pivot bolt
- (36) Clutch lever bracket
- (37) Clutch lever
- (38) Hex. nut (two)
- (39) Lever bracket holder (two)
- (40) Engine stop switch
- (41) Left handle grip rubber
- (42) Boot clamp (two)
- (43) Front fork assembly
- (44) Flange nut (four)
- (45) Brake cable clamp
- (46) Fork boot (two)
- (47) Fork bolt (two)
- (48) O-ring (two)
- (49) Fork spring A (two)
- (50) Upper spring seat (two)
- (51) Fork spring B (two)
- (52) Fork bolt lock nut (two)
- (53) Lower spring seat (two)
- (54) Front shock absorber complete (two)
- (55) Fork tube (two)
- (56) Oil lock piece (two)
- (57) Dust seal (two)
- (58) Internal circlip (two)
- (59) Oil seal (two)
- (60) Oil seal seat (two)
- (61) Fork slider
- (62) Sealing washer (two)
- (63) Allen head bolt (two)
- (64) Sealing washer (two)
- (65) Drain bolt (two)
- (66) Axle holder
- (67) Spring upper seat

Fig. 4-1

- (1) Flange bolt (four)
- (2) Upper holder (two)
- (3) Handlebar
- (4) Right handle grip rubber
- (5) Throttle grip pipe
- (6) Throttle grip housing A
- (7) Throttle grip housing B
- (8) Brake lever pivot bolt
- (9) Brake lever bracket
- (10) Lock nut
- (11) Front brake upper adjuster
- (12) Front brake lever
- (13) Brake lever cover
- (14) Throttle cable
- (15) Front brake cable
- (16) Stem nut
- (17) Plain washer
- (18) Fork top bridge

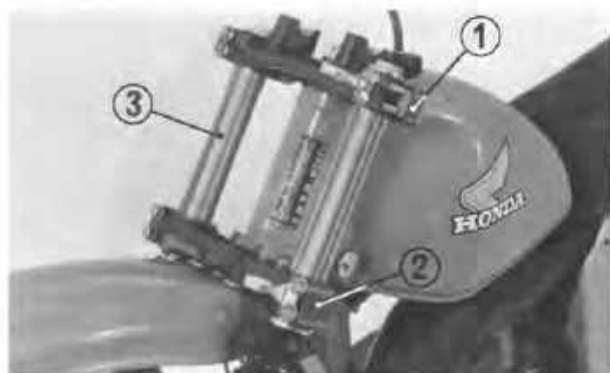

Fig. 4-2 (1) Fork top bridge
 (2) Fork bottom bridge
 (3) Front fork

Disassembly

1. Disconnect the front brake cable from the brake lever.
2. Disconnect the clutch cable from the clutch lever.
3. Remove the engine stop switch wiring connectors.
4. Disconnect the throttle cable from the throttle grip.
5. Remove the two upper holders and remove the handlebar.
6. Remove the front wheel (see page 41).
7. Loosen four 8 mm bolts at each front fork and pull down the forks.

8. Remove the steering stem nut and fork top bridge.
9. Remove the steering head bearing adjusting nut and pull out the steering stem.



Fig. 4-3 (1) Steering stem nut (2) Fork top bridge

10. Remove the steering stem bearing outer race with the ball race remover (Tool no. 07953-4300000).

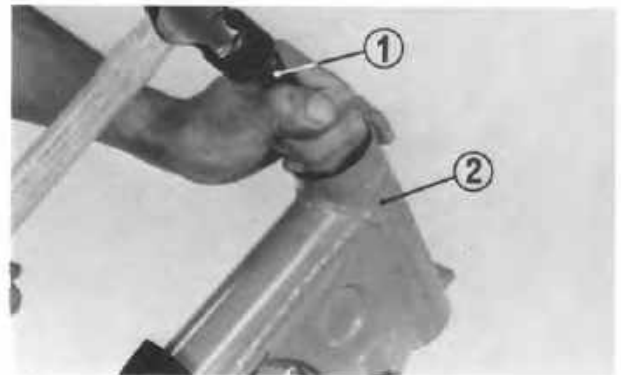

Fig. 4-4 (1) Ball race remover (2) Steering head

11. Loosen the fork bolt.
12. Remove the Allen head screw with the hollow set wrench (Tool no. 07917-3230000) and remove the oil lock piece, fork tube and front shock absorber.

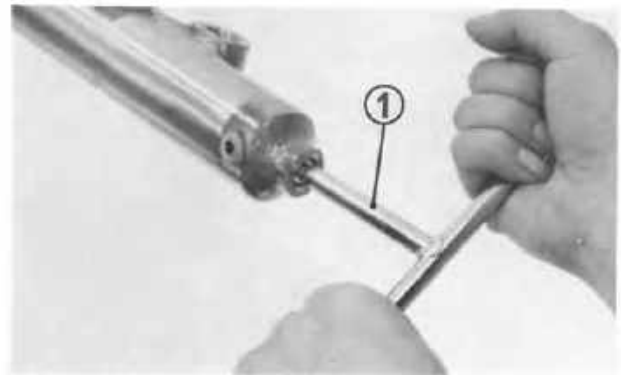

Fig. 4-5 (1) Hollow set wrench

13. Loosen the lock nut and remove the fork bolt, fork spring A, fork spring B, upper spring seat and lower spring seat.

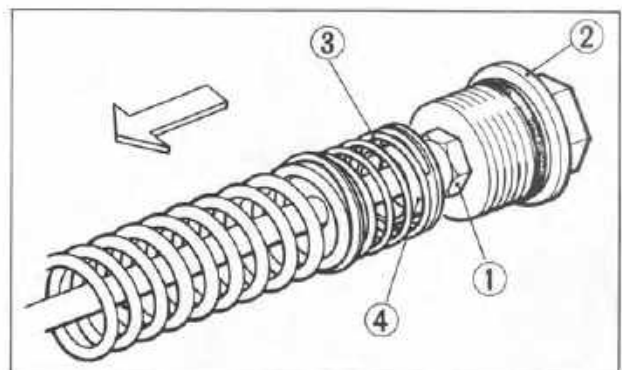

Fig. 4-6 (1) Lock nut (2) Fork bolt (3) Spring (4) Spring upper seat

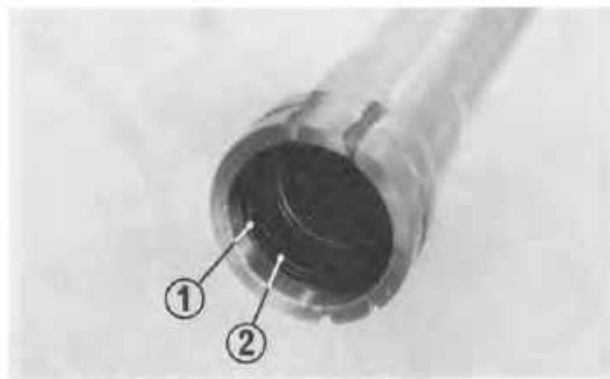

Fig. 4-7 (1) Internal circlip (2) Oil seal

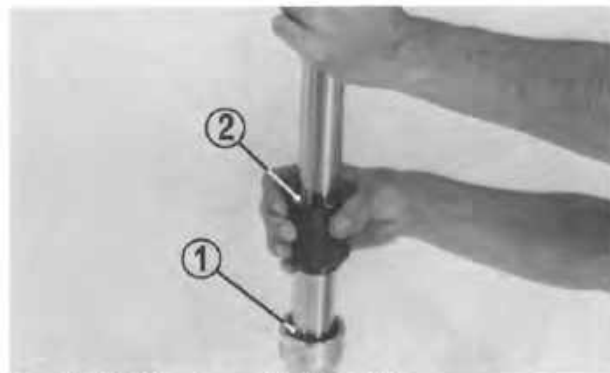

Fig. 4-8 (1) Oil seal (2) Oil seal driver

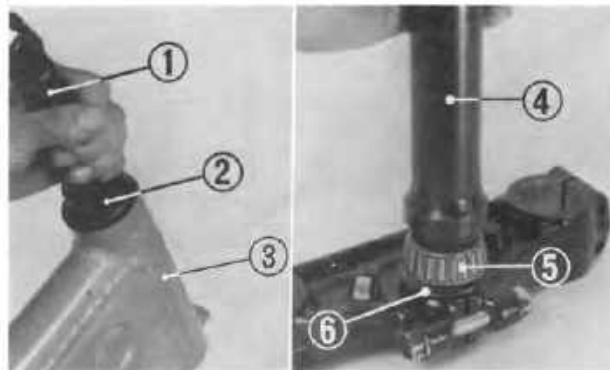

Fig. 4-9 (1) Driver handle (2) Bearing driver attachment (3) Steering stem head (4) Bearing driver (5) Bearing (6) Dust seal

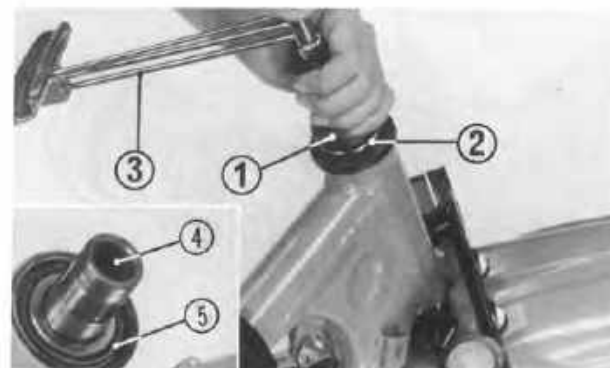

Fig. 4-10 (1) Steering stem socket wrench (2) Top thread nut (3) Torque wrench (4) Steering stem (5) Steering stem bearing

13. Remove the internal circlip and oil seal.

Inspection

1. Check the handlebar for bends or cracks.
2. Check the steering stem bearing for wear or cracks.
3. Check for accumulation of dirt in the boot. Clean, if necessary.
4. Measure the fork spring free length.

Service limit: Spring A: 41 mm (1.6 in.)

Spring B: 517.5 mm (20.37 in.)

Assembly

1. Apply locking sealant to the threads of the Allen head screw. Install the oil lock piece and fork piston and tighten with the Allen head screw.
2. Install the oil seal with the oil seal driver (Tool no. 07947-3710100) and install the internal circlip and dust seal.

3. Drive in the steering stem bearing outer race with the bearing driver (Tool no. 07946-4300200) and the driver handle (Tool no. 07949-6110000).
4. Drive the stem bearing on to the steering stem with the bearing driver (Tool no. 07946-4300100).
5. Apply grease on the bearings and install the steering stem into the steering head.

6. Tighten the steering stem adjusting nut with the steering stem socket wrench (Tool no. 07916-3710100).

Specified torque: 0.55–0.65 kg-m
(4.0–4.7 lb-ft)

7. Install the fork top bridge and front forks.

NOTE:

Align the top of the fork tube with the upper face of the fork top bridge.

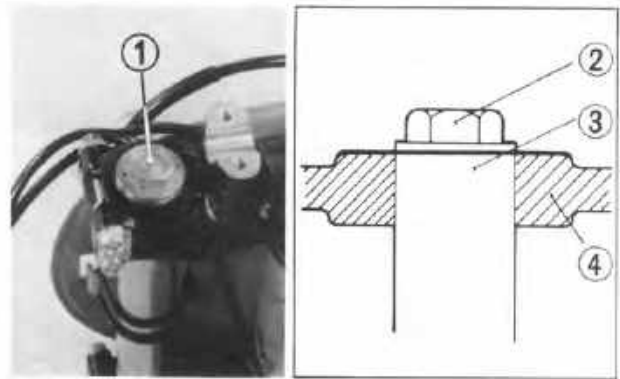

Fig. 4-11 (1) Front fork
(2) Fork bolt
(3) Fork pipe
(4) Fork top bridge

8. Install the handlebars and handlebar upper holders.

NOTE:

Install the handlebars with punch mark aligning with the top of handlebar holder.

Install the upper holder with the punch marks toward the front.

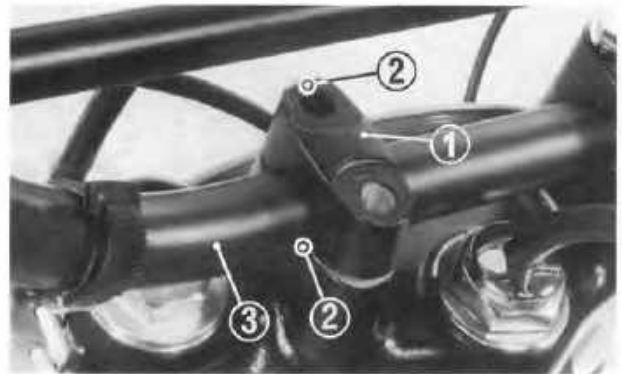

Fig. 4-12 (1) Handlebar upper holder
(2) Punch marks
(3) Handlebar

9. Route the throttle cable, front brake cable and clutch cable as shown in Fig. 4-13.



Fig. 4-13

10. Align the end face of the throttle grip housing with the punch mark on the handlebar as shown in Fig. 4-14, and tighten the two screws securely. Also, align the gaps of the front brake lever bracket and clutch lever bracket with the punch mark, and tighten the screw securely. Install the bracket holder with the punch mark facing up.

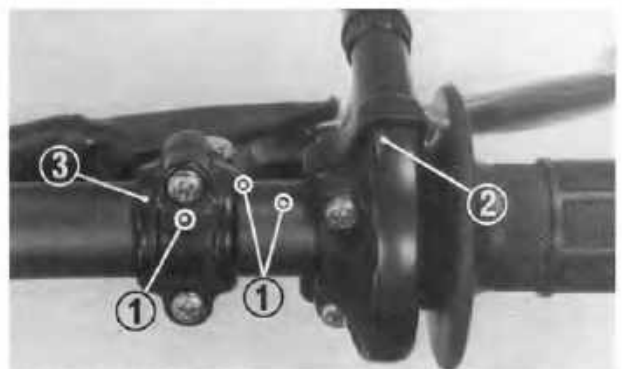

Fig. 4-14 (1) Punch marks
(2) Throttle grip housing
(3) Holder

2. REAR SUSPENSION

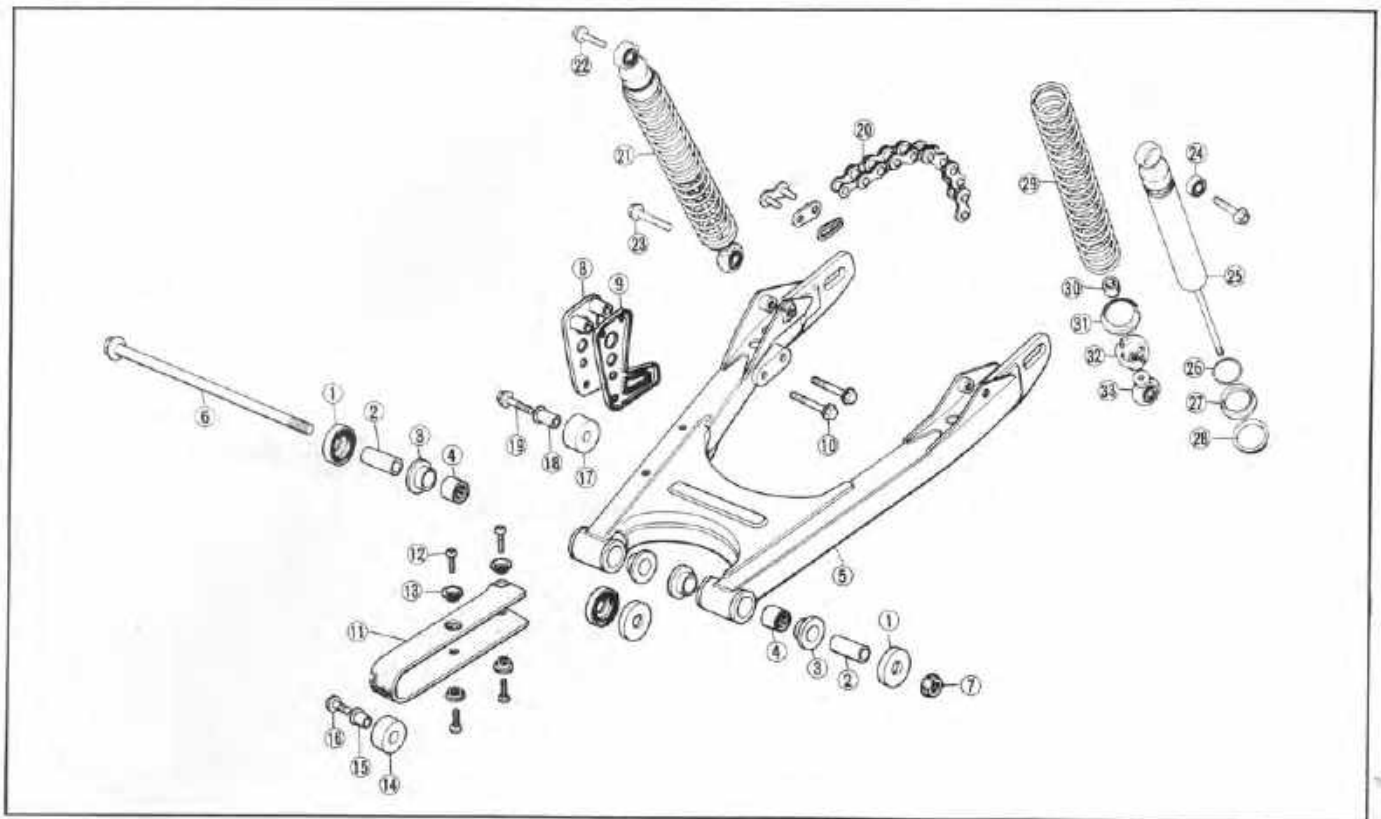
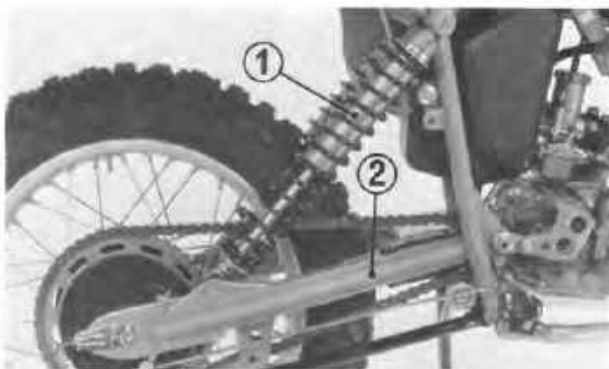

Fig. 4-15

- | | |
|--------------------------------|---|
| (1) Dust seal cap (two) | (18) Guide roller collar |
| (2) Pivot thrust collar (two) | (19) Bolt |
| (3) Bearing side collar (four) | (20) Drive chain |
| (4) Needle bearing (two) | (21) Rear shock absorber (two) |
| (5) Swing arm | (22) Upper bolt (two) |
| (6) Swing arm pivot bolt | (23) Lower bolt (two) |
| (7) Nut | (24) Rubber bush (two) |
| (8) Chain guide outer | (25) Rear shock absorber complete (two) |
| (9) Chain guide inner | (26) Stopper ring (two) |
| (10) Bolt (two) | (27) Spring adjuster (two) |
| (11) Chain slider | (28) Upper spring seat (two) |
| (12) Screw (four) | (29) Rear shock spring (two) |
| (13) Special washer | (30) Stopper rubber (two) |
| (14) Tensioner roller | (31) Lower spring seat (two) |
| (15) Tensioner roller collar | (32) Lock seat (two) |
| (16) Bolt | (33) Lower joint (two) |
| (17) Guide roller | |

Fig. 4-16 (1) Rear shock absorber
(2) Swing arm**Disassembly**

1. Place a wood block under the engine and remove the rear wheel (see page 54).
2. Remove the left and right side covers.
3. Remove the two rear shock absorber bolts, and remove the right and left rear shock absorbers.
4. Pull out the rear swing arm bolt and remove the swing arm.

- Compress the shock absorber spring to remove the lower spring seat.

Remove the shock spring, upper spring seat, spring adjuster and stopper ring.

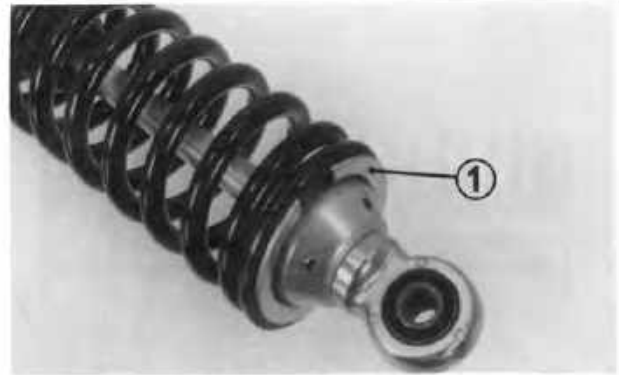

Fig. 4-17 (1) Lower spring seat

- Remove the joint, plain washer and lock seat with the pin spanner (Tool no. 07702-0010000).

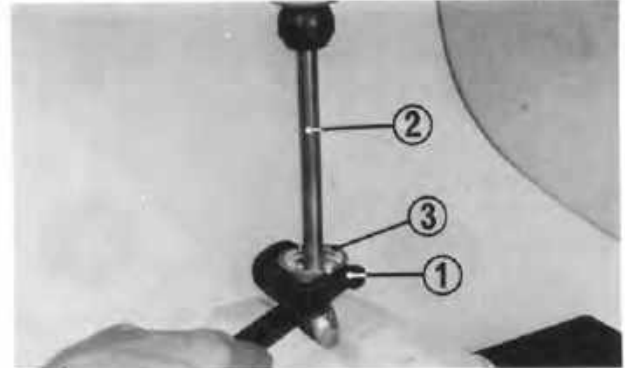

Fig. 4-18 (1) Pin spanner
(2) Rear shock absorber
(3) Lock seat

Inspection

- Visually inspect the damper unit for dents, holes or other defects. Replace the damper unit if necessary.
- Place the damper unit on a scale and measure the force required to compress the damper unit **10 mm (0.4 in.)**

Compression force: 7–10 kg (15.4–22.1 lbs)

If the compression force is less than **7 kg (15.4 lbs)**, gas leakage is indicated. Examine the damper rod and replace the damper unit if bent or scored.

WARNING

The rear shock absorbers contain nitrogen gas under high pressure. Do not attempt refilling or rebuilding since the shock absorbers may explode.

- Check to make sure that the rod moves up and down freely. It should return smoothly within approx. one second, when released.

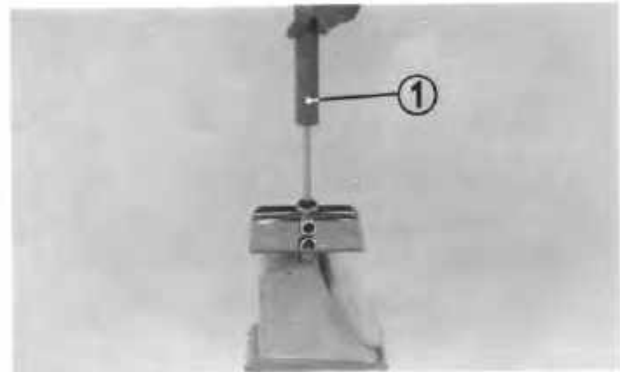

Fig. 4-19 (1) Damper unit

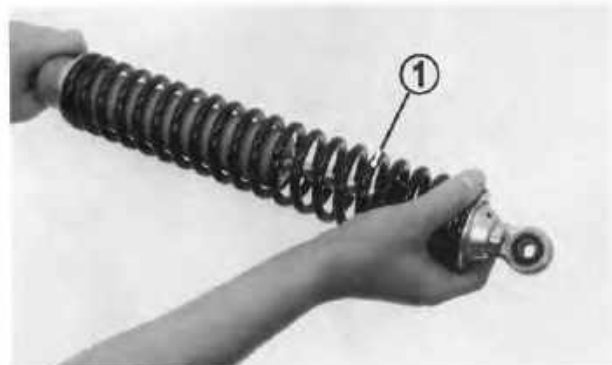

Fig. 4-20 (1) Spring

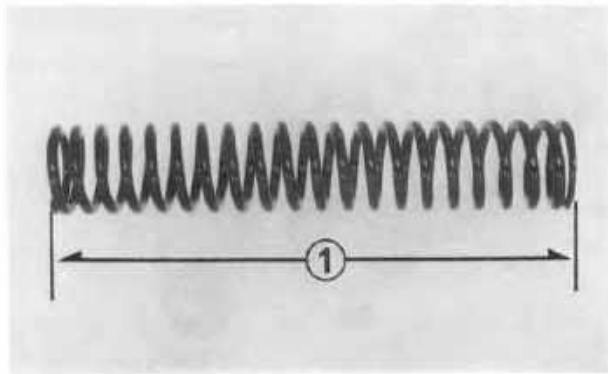

Fig. 4-21 (1) Spring free length

4. Measure the free length of the spring. Discard if the service limits are exceeded.

Service limit: 340 mm (13.3858 in.)

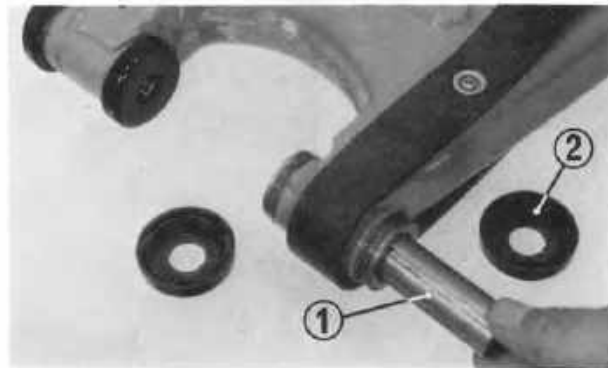

Fig. 4-22 (1) Thrust collar
(2) Dust seal

Assembly

Assembly is the reverse order of removal.

NOTE:

When installing the lower shock joint, apply an adhesive material on the threads. Tighten the joint to 3.8–6.0 kg-m (27.5–43.4 lb-ft).

Swing Arm

Tighten the swing arm pivot bolt until the swing arm will just drop under its own weight and there is no side play.

Apply a liberal coat of grease to the needle bearing thrust collar and to the lip and inside surface of the dust seal cap.

Specified torque: 6.0–8.0 kg-m (43.4–57.9 lb-ft)

3. FRONT WHEEL AND FRONT BRAKE

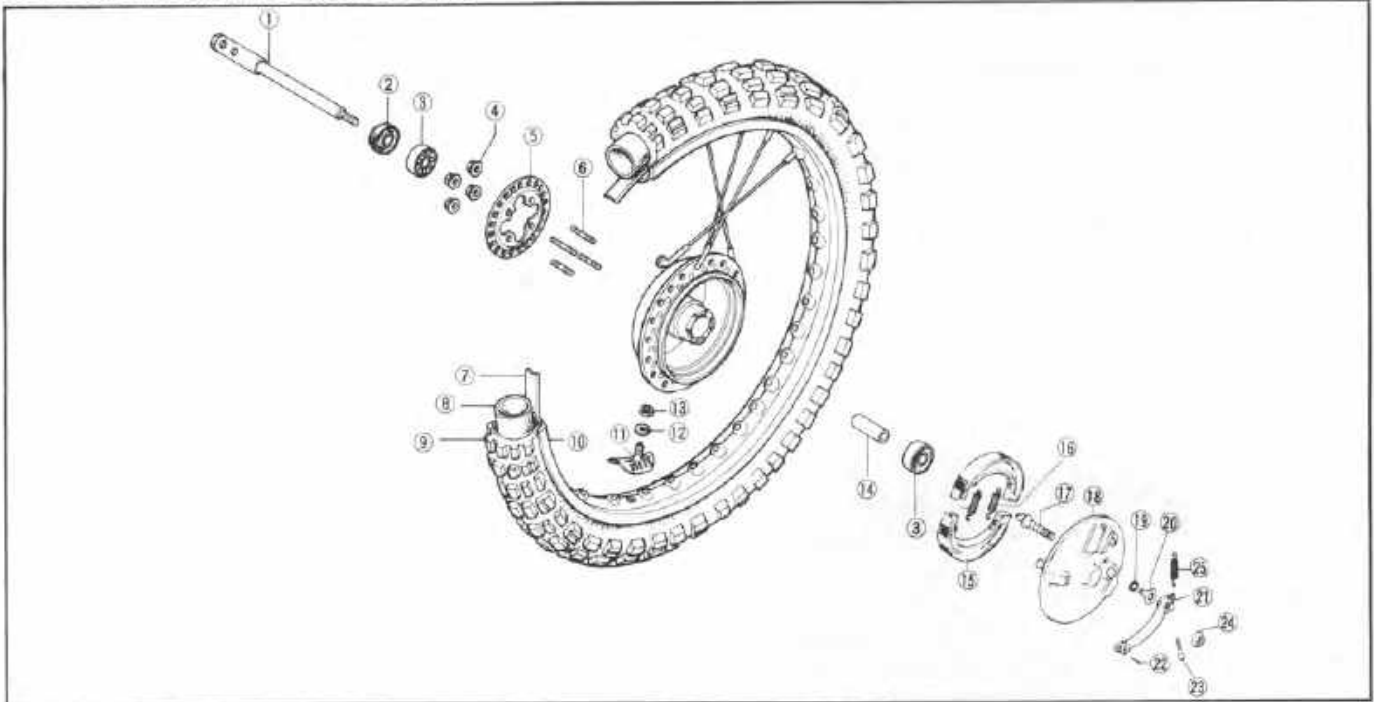

- Fig. 4-23**
- | | | |
|-----------------------------------|---------------------------------------|------------------------------|
| (1) Front wheel axle | (9) Front wheel tire
(3.00-21-4PR) | (17) Brake cam |
| (2) Dust seal | (10) Front wheel rim | (18) Front brake panel |
| (3) Bearing (two) | (11) Rim lock | (19) Dust seal |
| (4) Flange nut (four) | (12) Spring washer | (20) Indicator plate |
| (5) Spoke flange | (13) Hex. nut | (21) Brake arm |
| (6) Stud bolt (four) | (14) Side collar | (22) Cotter pin |
| (7) Tire flap | (15) Brake shoe (two) | (23) Bolt |
| (8) Front wheel tube
(3.00-21) | (16) Shoe spring (two) | (24) Axle nut |
| | | (25) Brake arm return spring |

Disassembly

- Place a support block under the engine and raise the front wheel off the ground.
- Pull out the cotter pin and disconnect the brake cable.
- Loosen the four nut on the right fork holder.
- Remove the axle nut and axle.

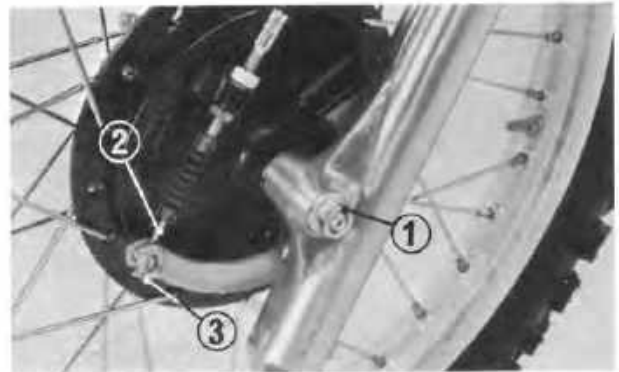

Fig. 4-24 (1) Axle nut
(2) Brake cable
(3) Cotter pin



Fig. 4-25 (1) Front axle

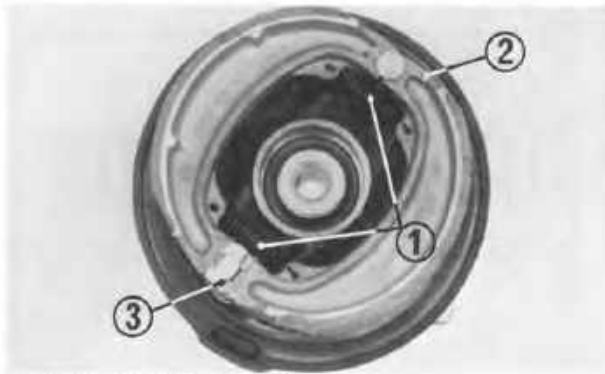

Fig. 4-26 (1) Brake shoe springs
(2) Brake shoe
(3) Brake cam

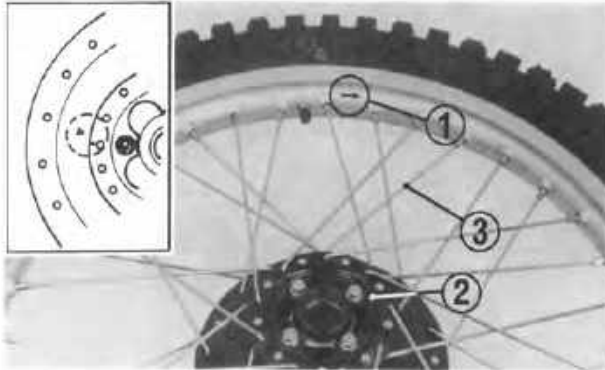

Fig. 4-27 (1) Arrow mark
(2) Spoke flange
(3) Spoke

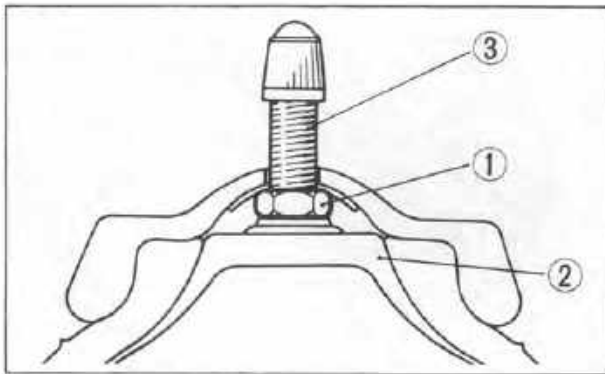

Fig. 4-28 (1) Valve nut
(2) Tire tube
(3) Valve

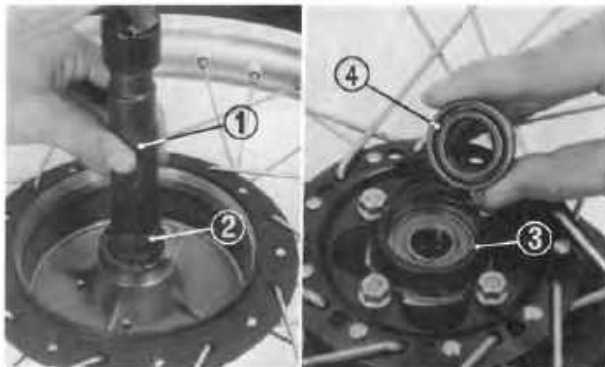

Fig. 4-29 (1) Driver handle
(2) Bearing driver
(3) Bearing
(4) Dust seal

5. Remove the brake shoes from the front brake panel.

Inspection

1. Check the front brake drum for wear.
2. Measure brake shoe thickness.
3. Check the brake cam for wear or cracks.
4. Check the front axle and replace if it is bent.
5. Check the brake shoe springs for fatigue or damage.

6. Check the front wheel rim for runout.
Service limit: 2.0 mm (0.08 in.)

Assembly

1. Install the spokes with the arrow marking on the wheel rim facing to the right (hub small flange side).

Specified torque:

Spoke nipple	0.25–0.5 kg-m (1.81–4.34 lb-ft)
Rim lock	1.0–1.5 kg-m (7.2–10.8 lb-ft)
Spoke flange	1.4–1.6 kg-m (10.1–11.6 lb-ft)

2. Install a valve nut when installing the tire tube as shown in Fig. 4-28.

3. Pack all bearing cavities with grease and install using the bearing driver (Tool no. 07746-010100) and driver handle (Tool no. 07949-6110000).

NOTE:

Drive in the right bearing first.

4. Coat the oil seal with grease and install.

5. Install the brake arm on the brake cam.



Fig. 4-30

6. Install the axle holder on the right fork leg with the mark "UPPER" facing upward. Do not tighten at this time.
7. Position the front wheel between the fork legs aligning the fork leg lug with the groove in the brake panel.

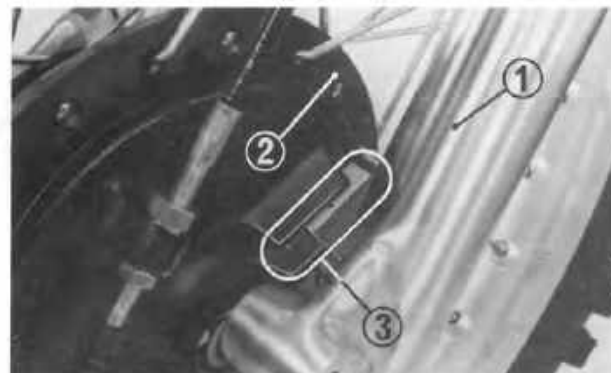

Fig. 4-31 (1) Front fork
(2) Brake panel
(3) Fitting point

8. Install the front axle.
Specified torque: 5.5–7.0 kg-m (39.8–50.6 lb-ft)
9. Tighten the front axle nut.
Specified torque: 5.5–7.0 kg-m (39.8–50.6 lb-ft)
10. Connect the front brake cable end to the brake arm.
11. Remove support from under the engine and apply the front brake. Tighten the axle holder nuts while pumping the front fork up and down several times.

Specified torque: 1.0–1.2 kg-m (7.2–8.7 lb-ft)

NOTE:

Tighten the upper holder nuts first and then the lower nuts.

CAUTION

Always replace used cotter pins with new ones.

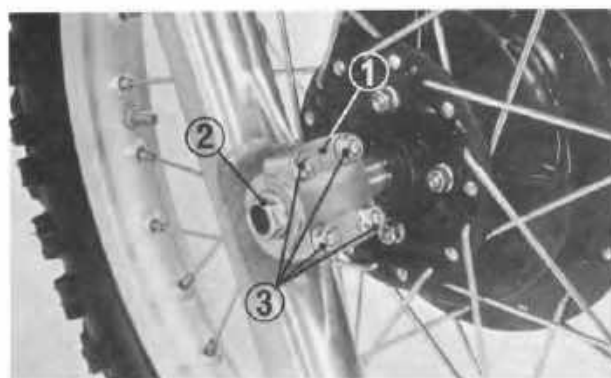
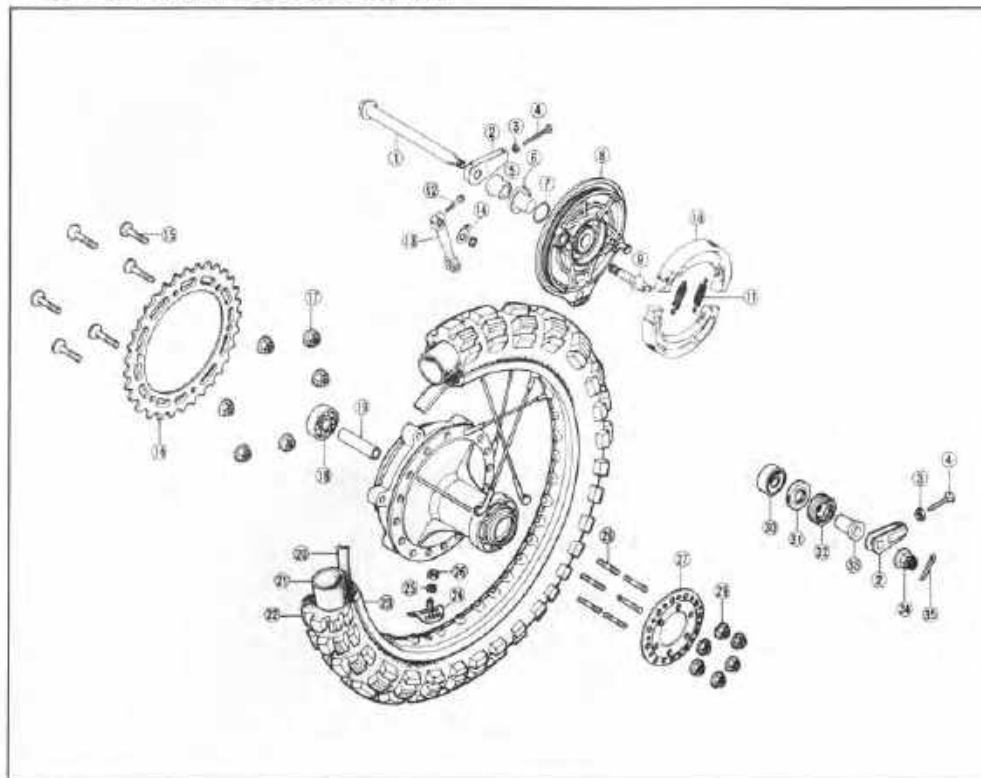

Fig. 4-32 (1) Axle holder
(2) Front axle
(3) Axle holder nuts

4. REAR WHEEL AND REAR BRAKE



- (1) Rear wheel axle
- (2) Drive chain adjuster (two)
- (3) Adjusting bolt lock nut (two)
- (4) Adjusting bolt (two)
- (5) Rear brake panel side collar
- (6) Rear brake panel bush
- (7) O-ring
- (8) Rear brake panel
- (9) Brake cam
- (10) Brake shoe (two)
- (11) Shoe spring (two)
- (12) Bolt
- (13) Rear brake arm
- (14) Indicator plate
- (15) Allen head bolt (six)
- (16) Driven sprocket
- (17) Flange nut (six)
- (18) Right wheel bearing
- (19) Distance collar
- (20) Tire flap
- (21) Rear wheel tube (5.10-18)
- (22) Rear wheel tire (5.10-18-4PR)
- (23) Rear wheel rim
- (24) Rim lock (two)
- (25) Spring washer (two)
- (26) Hex. nut (two)
- (27) Spoke flange
- (28) Stud bolt (six)
- (29) Flange nut (six)
- (30) Left wheel bearing
- (31) Dust seal
- (32) Bearing retainer
- (33) Rear wheel side collar
- (34) Axle nut
- (35) Cotter pin

Fig. 4-33

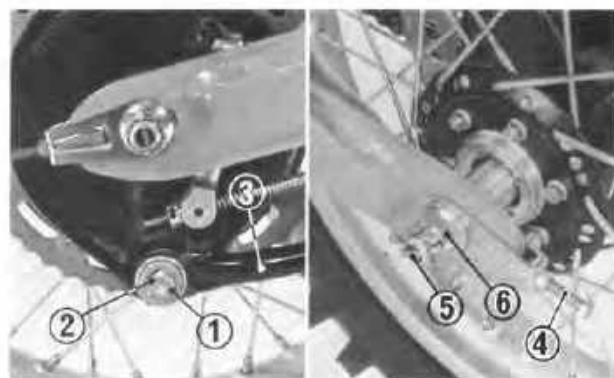

Fig. 4-34 (1) Cotter pin
 (2) Nut
 (3) Torque arm
 (4) Drive chain adjuster
 (5) Cotter pin
 (6) Axle nut



Fig. 4-35 (1) Retainer wrench

Disassembly

1. Place a wood block under the engine and raise the rear wheel off the ground.
2. Loosen the drive chain adjuster lock nut and bolt.
3. Remove the cotter pin from the rear axle nut.
4. Remove the master link clip and remove the drive chain.
5. Remove the torque arm cotter pin and the lock nut. Disconnect the torque arm.
6. Remove the rear axle, and remove the rear wheel.
7. Using the Allen wrench (Tool No. 07917-3230000) remove the six Allen head bolts and remove the driven sprocket.
8. Remove the bearing retainer with the retainer wrench (Tool no. 07919-430000).

9. Remove the brake panel, and then the brake shoes.

Inspection

1. Check the following items:

- Wear on brake drum
- Brake shoe thickness
- Wear or damage to brake cam
- Axle shaft bends
- Weakened brake shoe spring
- Wheel rim runout

Service limit: 2.0 mm (0.08 in.)

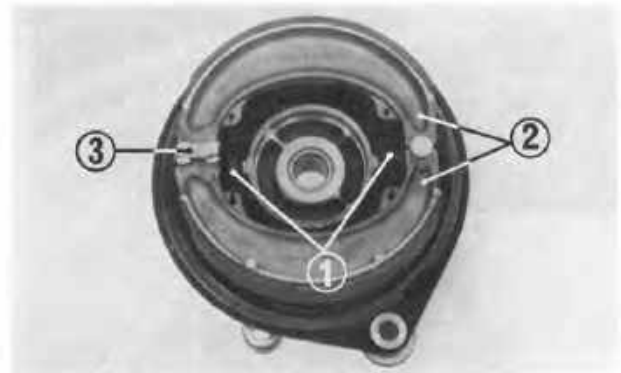

Fig. 4-36 (1) Brake shoe return spring
(2) Brake lining
(3) Brake cam

Assembly

1. Install the wheel with the arrow mark on the rim facing to the left.

Specified torque:

Spoke nipple	0.25-0.5 kg-m (1.81- 4.34 lb-ft)
Bead stopper	1.0 -1.5 kg-m (7.2 -10.8 lb-ft)
Spoke flange	1.4 -1.6 kg-m (10.1 -11.6 lb-ft)
Sprocket	3.2 -3.8 kg-m (23.1 -27.5 lb-ft)

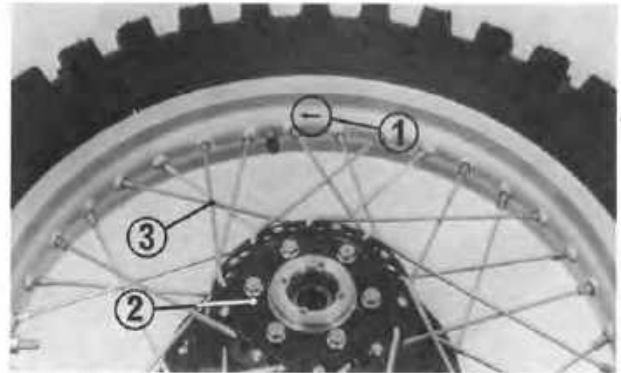

Fig. 4-37 (1) Arrow mark
(2) Hub flange
(3) Spoke

2. Install a valve nut when installing the tube as shown.

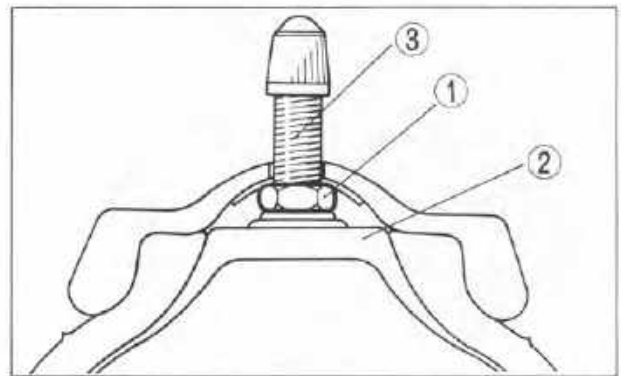

Fig. 4-38 (1) Valve nut
(2) Tube
(3) Valve

3. Drive the wheel bearings into their respective positions.

NOTE:

Drive in the left bearing first.

Special Tools

Bearing driver	Tool no. 07946-3290000	} Right side Left side
Driver handle	Tool no. 07949-6110000	
Bearing driver	Tool no. 07946-4300200	

NOTE:

- Pack all bearing cavities with grease before installation.
- Drive the bearing squarely.
- Install the bearing with the sealed end out.



Fig. 4-39 (1) Driver handle
(2) Bearing driver attachment

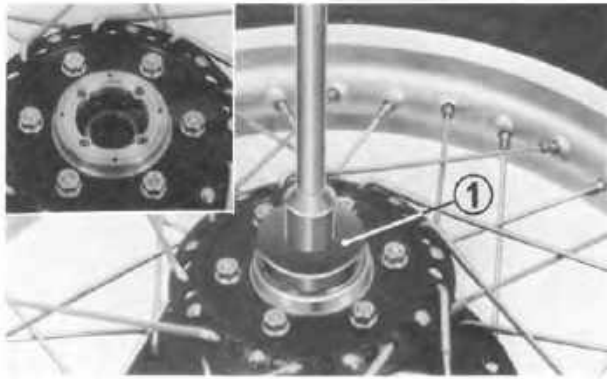

Fig. 4-40 (1) Retainer wrench

4. Install the bearing retainer with the retainer wrench (tool no. 07919-4300000).

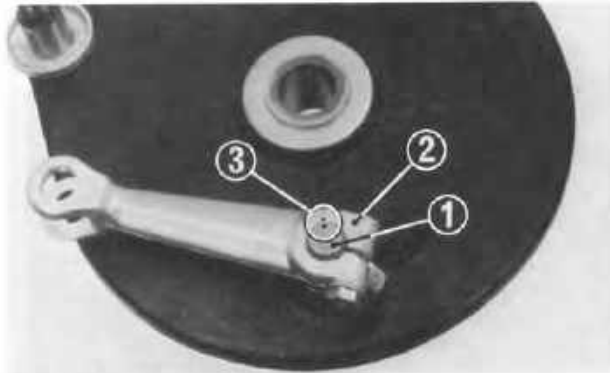

Fig. 4-41 (1) Brake arm
(2) Brake cam
(3) Punch mark

5. Install the brake arm.

NOTE:

Align the punch mark on the brake arm with the punch mark on the brake cam.

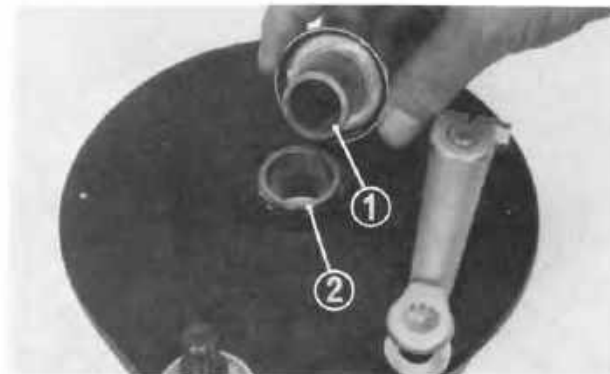

Fig. 4-42 (1) Bushing (2) Brake panel

6. Lubricate the brake panel bushing with grease and install.

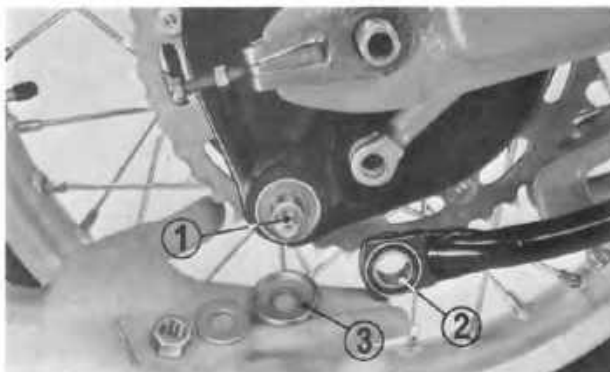

Fig. 4-43 (1) Torque arm pivot bolt
(2) Torque arm
(3) Dust seal

7. Install the rear wheel, brake rod and torque arm.

NOTE:

Lubricate the inside of the torque arm pivot and O-ring with grease.

8. Adjust the drive chain slack, and then install the axle nut. Adjust the rear brake (Page 16).

Specified torque:

Rear axle nut 8.0–10.0 kg (57.9–72.3 lb-ft)

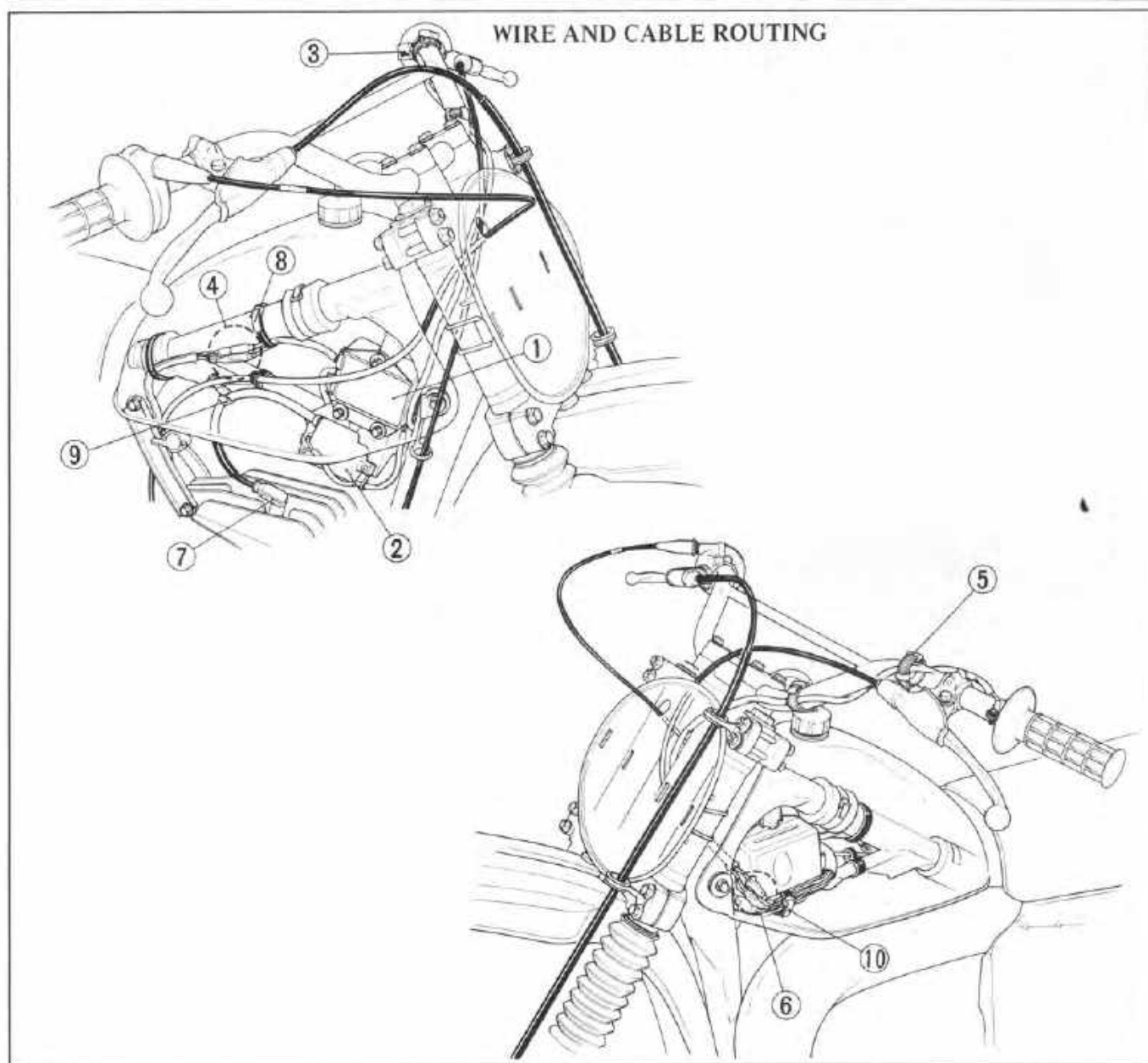

Fig. 5-1

- (1) C.D.I. unit
- (2) Ignition coil
- (3) Engine stop switch
- (4) A.C. generator wire connector
- (5) Wire harness band

- (6) Ignition coil wire and engine stop switch wire connectors
- (7) Plug cap
- (8) Wire harness band
- (9) High tension lead
- (10) Wire harness band

1. A.C. GENERATOR

Disassembly

1. Disconnect the A.C. generator wire connectors.
2. Remove the A.C. generator cover.

CAUTION

Do not disassemble the stator coil from A.C. generator cover.



Fig. 5-2

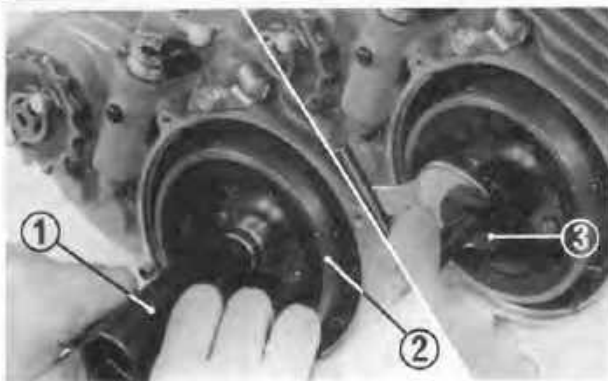

Fig. 5-3 (1) 17 mm wrench
(2) A.C. generator rotor
(3) Rotor puller

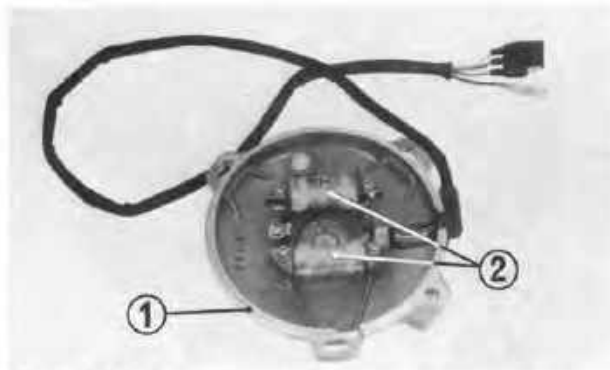

Fig. 5-4 (1) A.C. generator cover
(2) Stator coil

- Remove the rotor bolt with 17 mm wrench and remove the rotor with rotor puller (Tool no. 07933-4300000).

Inspection

Measure resistances between the terminals:
Replace the A.C. generator Assy., if the readings do not fall within the limits below.

Terminal	Resistance	
	SANWA	KOWA
Blue - White	*120Ω ± 10%	118Ω ± 10%
Blue - Green	26Ω ± 10%	26Ω ± 10%
Blue - Red	*145Ω ± 10%	145Ω ± 10%
White - Green	* 92Ω ± 10%	92Ω ± 10%
White - Red	25Ω ± 10%	25Ω ± 10%
Green - Red	*117Ω ± 10%	120Ω ± 10%

- Use SANWA ELECTRICAL TESTER (P/N 07308-0020000) or KOWA ELECTRICAL TESTER (TH-5H. MEASURING RANGE: x 1Ω (*: 10Ω))

2. C.D.I. UNIT

Inspection

- The C.D.I. unit is fully transistorized. For accurate testing, it is necessary to use a specified electrical tester. Use of an improper tester or measurements in improper range may give false readings.
- Use SANWA ELECTRICAL TESTER (P/N 07308-0020000) or KOWA ELECTRICAL TESTER (TH-5H).

UPPER ROW: MEASURING RANGE
(SANWA TESTER) x kΩ
LOWER ROW: MEASURING RANGE
(KOWA TESTER) x 100Ω

Probe (+) Probe (-)	A.C. Generator cord				Engine stop switch cord		Ignition coil cord	
	Blue	White	Green	Red	Green	Black/White	White/Blue	Green
A.C. Generator cord	Blue	∞	∞	∞	∞	∞	∞	∞
	White	∞	∞	∞	∞	∞	∞	∞
	Green	13 - 22 60 - 90	3.2 - 4.5 8 - 14	∞	∞	0	∞	∞
	Red	∞	∞	∞	∞	∞	∞	∞
Engine stop switch cord	Green	13 - 22 60 - 90	3.2 - 4.5 8 - 14	0	∞	∞	∞	0
	Black/White	∞	∞	∞	∞	∞	∞	∞
Ignition coil cord	White/Blue	38 - 50 150 - 300	9 - 17 28 - 36	3.0 - 4.2 7.5 - 12	∞	3.0 - 4.2 7.5 - 12	∞	3.0 - 4.2 7.5 - 12
	Green	13 - 22 60 - 90	3.2 - 4.5 8 - 14	0	∞	0	∞	∞

The resistances shown in the table indicate those to be read on the tester, not of specific circuits or parts.

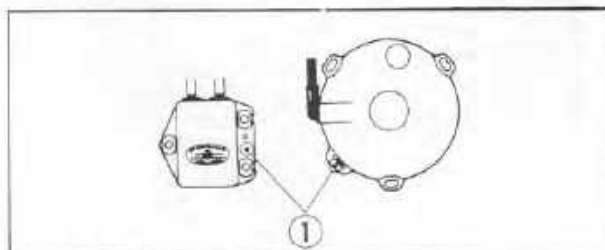

Fig. 5-5 (1) Code mark

CAUTION

The C.D.I. unit is a selective use with the A.C. generator and is letter coded. When replacing either the C.D.I. unit or A.C. generator, check that the letter code (D, E or F) on the new unit agrees with that on the corresponding C.D.I. unit or A.C. generator.

I. OPTIONAL PARTS LIST

Item	Remarks																																																														
<p>FRAME:</p> <ul style="list-style-type: none"> • Driven sprocket • Drive chain • Spark arrester • Center stand • Front fork spring B • Rear shock spring 	<p>Aluminum, 51T/53T (Standard: 49T) Steel, 49T (Mud/sand)</p> <p>110 links (Standard: 108 links)</p> <p>For maintenance service</p> <p>Harder</p> <p>Harder (red point marking) Softer (White point marking)</p>																																																														
<p>ENGINE:</p> <ul style="list-style-type: none"> • Drive sprocket • Carburetor setting parts <p style="padding-left: 20px;">Main jet</p> <p style="padding-left: 20px;">Jet needle</p> <p style="padding-left: 20px;">Throttle valve</p> <p style="padding-left: 20px;">Slow jet</p>	<p>15T (Standard: 14T)</p> <p>#170–#200 (Every #2 or #3) (13 sizes) Standard: #185</p>  <p>Standard: 28A (1°30'–2.725)</p> <p>Optional jet needles for CR250R carburetors are available in nine different profiles which combine any of three straight diameters with any of three taper angles.</p>  <table border="1" data-bbox="950 987 1429 1186"> <thead> <tr> <th>STRAIGHT DIAMETER</th> <th>TAPER ANGLE</th> <th>MIXTURE AT APPLICABLE THROTTLE OPENING</th> </tr> </thead> <tbody> <tr> <td>2.745 mm</td> <td>1°15'</td> <td>Leaner</td> </tr> <tr> <td>2.725 mm</td> <td>1°30'</td> <td>Standard</td> </tr> <tr> <td>2.705 mm</td> <td>1°45'</td> <td>Richer</td> </tr> </tbody> </table> <table border="1" data-bbox="560 1218 1429 1564"> <thead> <tr> <th>H/C</th> <th>PART NUMBER</th> <th>DESCRIPTION</th> <th>STRAIGHT DIAMETER</th> <th>TAPER ANGLE</th> </tr> </thead> <tbody> <tr> <td>67856</td> <td>16201-430-000</td> <td>Jet Needle 31A</td> <td>2.705 mm</td> <td>1° 15'</td> </tr> <tr> <td>67857</td> <td>16202-430-000</td> <td>Jet Needle 31B</td> <td>2.725 mm</td> <td>1° 15'</td> </tr> <tr> <td>67858</td> <td>16203-430-000</td> <td>Jet Needle 31C</td> <td>2.745 mm</td> <td>1° 15'</td> </tr> <tr> <td>67859</td> <td>16204-430-000</td> <td>Jet Needle 31D</td> <td>2.705 mm</td> <td>1° 30'</td> </tr> <tr> <td>67860</td> <td>16205-430-000</td> <td>Jet Needle 31E*</td> <td>2.725 mm</td> <td>1° 30'</td> </tr> <tr> <td>67861</td> <td>16206-430-000</td> <td>Jet Needle 31F</td> <td>2.745 mm</td> <td>1° 30'</td> </tr> <tr> <td>67862</td> <td>16207-430-000</td> <td>Jet Needle 31G</td> <td>2.705 mm</td> <td>1° 45'</td> </tr> <tr> <td>67863</td> <td>16208-430-000</td> <td>Jet Needle 31H</td> <td>2.725 mm</td> <td>1° 45'</td> </tr> <tr> <td>67864</td> <td>16209-430-000</td> <td>Jet Needle 31J</td> <td>2.745 mm</td> <td>1° 45'</td> </tr> </tbody> </table> <p>*Optional jet needle 31E has the same profile as standard jet needle 28A.</p> <p>#2.0–#3.0 (Cutaway: Every #0.5) (3 sizes) Standard: #2.5</p>  <p>#55 – #65 (Every #5) (3 sizes) Standard: #60</p>	STRAIGHT DIAMETER	TAPER ANGLE	MIXTURE AT APPLICABLE THROTTLE OPENING	2.745 mm	1°15'	Leaner	2.725 mm	1°30'	Standard	2.705 mm	1°45'	Richer	H/C	PART NUMBER	DESCRIPTION	STRAIGHT DIAMETER	TAPER ANGLE	67856	16201-430-000	Jet Needle 31A	2.705 mm	1° 15'	67857	16202-430-000	Jet Needle 31B	2.725 mm	1° 15'	67858	16203-430-000	Jet Needle 31C	2.745 mm	1° 15'	67859	16204-430-000	Jet Needle 31D	2.705 mm	1° 30'	67860	16205-430-000	Jet Needle 31E*	2.725 mm	1° 30'	67861	16206-430-000	Jet Needle 31F	2.745 mm	1° 30'	67862	16207-430-000	Jet Needle 31G	2.705 mm	1° 45'	67863	16208-430-000	Jet Needle 31H	2.725 mm	1° 45'	67864	16209-430-000	Jet Needle 31J	2.745 mm	1° 45'
STRAIGHT DIAMETER	TAPER ANGLE	MIXTURE AT APPLICABLE THROTTLE OPENING																																																													
2.745 mm	1°15'	Leaner																																																													
2.725 mm	1°30'	Standard																																																													
2.705 mm	1°45'	Richer																																																													
H/C	PART NUMBER	DESCRIPTION	STRAIGHT DIAMETER	TAPER ANGLE																																																											
67856	16201-430-000	Jet Needle 31A	2.705 mm	1° 15'																																																											
67857	16202-430-000	Jet Needle 31B	2.725 mm	1° 15'																																																											
67858	16203-430-000	Jet Needle 31C	2.745 mm	1° 15'																																																											
67859	16204-430-000	Jet Needle 31D	2.705 mm	1° 30'																																																											
67860	16205-430-000	Jet Needle 31E*	2.725 mm	1° 30'																																																											
67861	16206-430-000	Jet Needle 31F	2.745 mm	1° 30'																																																											
67862	16207-430-000	Jet Needle 31G	2.705 mm	1° 45'																																																											
67863	16208-430-000	Jet Needle 31H	2.725 mm	1° 45'																																																											
67864	16209-430-000	Jet Needle 31J	2.745 mm	1° 45'																																																											



Fig. 6-1 (1) Seat (2) Left side cover

2. SPARK ARRESTER/MUFFLER INSTALLATION

1. Remove the seat and left side cover, then remove the expansion spring.

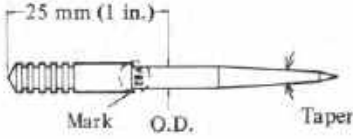
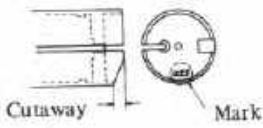
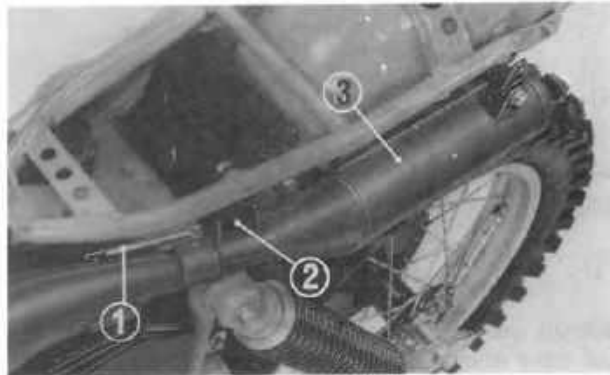

Fig. 6-2 (1) Spring (2) Bolt (3) Sub muffler

2. Remove the bolt attaching the muffler, and take off the muffler.



Fig. 6-3 (1) Rubber protector
(2) Muffler hanger
(3) Spark arrester

3. Install the gasket and rubber protector to the spark arrester/muffler.



Fig. 6-4 (1) Spring

4. Tighten the bolt and install the spring. Install the seat and left side cover.

3. CARBURETOR SETTINGS

The carburetor used on the CR250R ELSINORE will seldom experience trouble with the standard settings under average load, climatic and barometric conditions. However, in order to tune up the engine to the best advantage as regards power output, it is essential that the carburetor be adjusted according to the specific racing conditions. This instruction concerns the CARBURETOR RACING KIT for the CR250R ELSINORE and will prove of much help in diagnosing troubles resulting from improper carburetor settings.

Carburetor Settings and Trouble Diagnosis

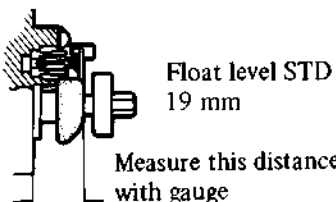
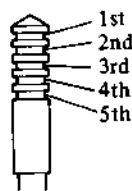
Symptom	Remedy	Remarks
Mixture Lean at Full Throttle • Hunting • White or light gray spark plug insulator • Detonation	<ul style="list-style-type: none"> • Try with #2 or #3 higher main jet. • Adjustment is normal if there are rusty brown to grayish-tan powder deposits on spark plug electrodes and insulator. • Check float valve seat, fuel line and fuel cock for clogging if mixture is still lean with #10 higher main jet. 	<ul style="list-style-type: none"> • Check for advanced timing • Check for air leaking into intake manifold • Check for loose air cleaner • Check for primary compression leak
Mixture Rich at Full Throttle • Poor acceleration • Lack of power • Sooty deposits on spark plug electrodes and insulator	<ul style="list-style-type: none"> • Replace with lower main jet. • Adjustment is normal if there are rusty brown to grayish-tan powder deposits on spark plug electrodes and insulator. <p>NOTE: A slightly rich mixture is preferable to reduce possible troubles associated with overheating.</p>	<ul style="list-style-type: none"> • Check ignition timing • Check for clogged air cleaner • Check for insufficient returning of starter valve • Check for excessively high fuel level.
Mixture Rich at All Speeds	<ul style="list-style-type: none"> • Lower float level by 2 mm and try with #5 lower or raise main jet. 	<ul style="list-style-type: none"> • Check for correct main jet (too high number)
Mixture Lean at 1/4 Throttle (Follows steps in reverse if mixture is rich)	<ul style="list-style-type: none"> • Replace jet needle with greater taper needle 21A (1°30') → 31H (1°45'). At the same time, lower main jet size by #5. 	
Mixture Lean at 1/2 Throttle (Follow steps in reverse if mixture is rich)	<ul style="list-style-type: none"> • Raise jet needle by 1 stage. (3rd → 4th) • Try with #2 or #3 lower main jet if jet needle is raised by more than 2 grooves. 	<ul style="list-style-type: none"> • Grooves are counted from top 
Mixture Lean at 0-1/4 Throttle	<ul style="list-style-type: none"> • Try with narrower straight dia. jet needle. (21A) (31E) (2.725 mm) → 31D (2.705 mm) 	<ul style="list-style-type: none"> • Make sure that air screw opening is within specs 1-1/2 turns out
Mixture Rich at 0-1/4	<ul style="list-style-type: none"> • Replace with greater straight dia. jet needle. (21A) (31E) (2.725 mm) → 31F (2.745 mm) 	<ul style="list-style-type: none"> • Same as above
Erratic or Unstable Performance at Low Speeds With Detonation.	<ul style="list-style-type: none"> • Raise jet needle by 1 groove. (2nd → 3rd) • Try with narrower straight dia. jet needle. • Turn in air screw 1/2 rotation. 	

Symptom	Remedy	Remarks
Mixture Rich at Very Low Speeds (Poor throttle response)	<ul style="list-style-type: none"> Try with greater straight dia. jet needle. Screw air screw out as necessary. If symptom still persists, reverse above procedure. 	<ul style="list-style-type: none"> Check for dragging brake Check for excessively high fuel level
Mixture Rich at Low Speed (Poor throttle response)	<ul style="list-style-type: none"> Lower jet needle. If symptom still persists, reverse above step. 	<ul style="list-style-type: none"> Same as above
Engine Does Not Slow Down Smoothly	<ul style="list-style-type: none"> Screw in air screw 1/4–1/2 turn or check for air leak 	<ul style="list-style-type: none"> Check throttle valve for binding
Mixture Rich at 1/4 – 3/4 Throttle Poor Engine Response to Throttle	<ul style="list-style-type: none"> Increase throttle valve cutaway. (#2.5 – #3.0) Decrease throttle valve cutaway if mixture is lean 	
Engine does not React to Air Screw Adjustments	<ul style="list-style-type: none"> Change Pilot Jet 	

Carburetor Setting Hints

Condition	Measure	Remarks
At High Altitude	<ul style="list-style-type: none"> Lean out mixture by lowering main jet number (by #5 or #8 for every 1000 m increase in altitude) Lower jet needle by 1 groove. (2nd → 1st) 	
At High Temperature (35° – 40°C)	<ul style="list-style-type: none"> Lean out enriched mixture by lowering main jet number by #3 or #5. 	
At Low Temperature (0° – 10°C)	<ul style="list-style-type: none"> Enrich leaned mixture by using #3 or #5 higher main jet. 	
In Rain, High Temperature	<ul style="list-style-type: none"> Replace with #2 or #3 lower main jet. 	<ul style="list-style-type: none"> Make sure that there is no water in fuel
On Marshy, Slippery Surfaces or on Sands, or with Frequent or Long Upgrades	<ul style="list-style-type: none"> Use higher main jet. Raise jet needle by 1–2 grooves to enrich mixture. (2nd → 3rd) 	<ul style="list-style-type: none"> Engine tends to overheat. Slightly retard engine response to throttle for easier maneuver
Fine Day, Marshy or Slippery Surfaces	<ul style="list-style-type: none"> Use #2 or #3 higher main jet. 	<ul style="list-style-type: none"> To cope with reduced heat radiation from cylinders
Under Dusty Conditions	<ul style="list-style-type: none"> Check for clogged air cleaner. Do not use lower main jet to compensate for clogged air cleaner. 	<ul style="list-style-type: none"> Adjust carburetor when air cleaner is clean
On High Speed Runways	<ul style="list-style-type: none"> Use #2 or #3 higher main jet than at best test trial. 	<ul style="list-style-type: none"> To prevent engine overheating

4. CYLINDER

The chrome-plated cylinder resists wear, contributes to lighter construction and improves cooling. The cylinder must not be rebored nor the intake and exhaust ports reworked as such practices will only impair the engine performance. After replacing the cylinder, operate the motorcycle for the first hour using not more than half throttle as described in **BREAKING—IN THE MOTORCYCLE** on page 4. Note that oversize pistons and piston rings are not available for the engine.

NOTE:

Always use the piston rings designed specifically for the cylinder. Specially treated, the rings will ensure good conformity to the contour of the cylinder wall within the shortest possible period.

1. TROUBLESHOOTING

Trouble	Cause	Remedy
Engine fails to start or does not start easily.	1. Insufficient compression pressure (1) Crankcase compression leak at oil seal (2) Crankcase compression leak at crankcase mating surfaces (3) Worn or stuck piston rings (4) Worn cylinder 2. No spark at plug (1) Fouled plug (2) Wet plug (3) Poor connections (4) Faulty C.D.I. unit (5) Incorrect ignition timing (6) Faulty ignition coil (7) Open or short circuit in ignition wires (8) Short circuit in A.C. generator 3. Raw gas in crankcase 4. No fuel is fed to carburetor (1) Broken or clogged fuel cap breather tube (2) Clogged fuel cock (3) Faulty carburetor float valve (4) Clogged fuel tube 5. Deteriorated fuel-oil mixture	Replace Repair Replace Replace Clean or replace Clean or replace Replace Replace Replace Replace Replace Replace Remove gas (with fuel cock in "OFF" position after stopping the engine) Repair Clean Clean or replace Clean Replace
Engine stalls frequently.	1. Fouled plug 2. Incorrect ignition timing 3. Clogged fuel lines 4. Clogged carburetor jets 5. Crankcase compression leak 6. Intake manifold leak 7. Deteriorated fuel-oil mixture	Clean or replace Replace Clean Clean Repair Repair or replace Replace
Engine does not have sufficient power.	1. Worn cylinder and worn or stuck piston rings 2. Incorrect ignition timing 3. Incorrect plug gap 4. Clogged carburetor jets 5. Incorrect float height 6. Clogged air cleaner 7. Cracked expansion chamber 8. Deteriorated fuel-oil mixture	Repair or replace Replace Repair or replace Clean Adjust Clean or replace Repair or replace Replace
Engine overheats.	1. Carbon deposits on cylinder head 2. Lean fuel mixture 3. Overadvanced ignition timing 4. Carbon deposits in expansion chamber 5. Deteriorated gasoline	Clean Adjust Replace Clean Replace

Trouble	Cause	Remedy
Clutch slips.	<ol style="list-style-type: none"> 1. Weak clutch springs 2. Worn or deformed pressure plate 3. Deformed clutch plates 4. Worn or deformed friction discs 	Replace Replace Replace Replace
Clutch drags.	<ol style="list-style-type: none"> 1. Unequal clutch spring tension 2. Deformed clutch plates 	Replace Replace
Transmission gears fail to shift smoothly or sequentially.	<ol style="list-style-type: none"> 1. Deformed shift drum stopper 2. Broken shift drum 3. Deformed shift forks 4. Weak shift drum stopper spring 	Repair or replace Replace Repair or replace Replace
Change pedal fails to return.	<ol style="list-style-type: none"> 1. Broken gearshift return spring 2. Contact between cases and gearshift spindle 	Repair or replace Repair
Transmission gears disengage accidentally.	<ol style="list-style-type: none"> 1. Worn main shaft and countershaft shifting gears 2. Bent or worn gearshift forks 	Replace Repair or replace
Engine operation is erratic at low speeds.	<ol style="list-style-type: none"> 1. Incorrect ignition timing 2. Excessive plug gap 3. Weak spark (defective ignition coil) 4. Short circuit in A.C. generator 5. Incorrect float level 6. Incorrect carburetor air screw adjustment 	Replace Adjust or replace Replace Repair or replace Adjust Adjust
Engine operation is erratic at high speeds.	<ol style="list-style-type: none"> 1. Insufficient plug gap 2. Retarded ignition timing 3. Faulty C.D.I. unit 4. Faulty ignition coil 5. Incorrect float level 6. Clogged air cleaner element 7. Crankcase compression leak 8. Short circuit in A.C. generator 9. Broken or cracked expansion chamber, broken tail pipe or carbon deposit 	Adjust or replace Replace Replace Replace Adjust Clean or replace Repair Repair or replace Repair or replace
Engine fails to fire.	<ol style="list-style-type: none"> 1. Fouled spark plug 2. Faulty ignition coil 3. Faulty C.D.I. unit 4. Short circuit in A.C. generator 	Replace Replace Replace Replace
Spark plug electrodes are fouled.	<ol style="list-style-type: none"> 1. Rich mixture (rich carburetion or clogged air filter) 2. Incorrect gasoline and oil mixing ratio 3. Incorrect spark plug heat range 	Adjust or clean Replace Replace
Spark plug electrodes are burnt.	<ol style="list-style-type: none"> 1. Incorrect heat range 2. Overheating engine 3. Incorrect ignition timing 4. Loose spark plug 5. Lean mixture 	Use specified plug Page 63 Replace Retighten Adjust

Trouble	Cause	Remedy
Steering is hard.	<ol style="list-style-type: none"> 1. Overtightened steering stem 2. Broken steering stem bearing 3. Bent steering stem 	Adjust Replace Replace
Front wheel shimmys.	<ol style="list-style-type: none"> 1. Deformed rim 2. Loose front wheel bearings 3. Loose spokes 4. Loose axle and related parts 	Replace Replace Adjust Retighten
Front suspension is spongy.	<ol style="list-style-type: none"> 1. Weak springs 2. Insufficient front fork oil 	Replace Add
Front suspension is hard.	<ol style="list-style-type: none"> 1. Incorrect front fork oil; viscosity too high 2. Excessive front fork fluid 	Replace Adjust
Rear wheel shimmys.	<ol style="list-style-type: none"> 1. Deformed rim 2. Loose rear wheel bearings 3. Loose spokes 4. Loose axle and related parts 	Replace Replace Adjust Retighten
Rear suspension is spongy.	<ol style="list-style-type: none"> 1. Weak springs 2. Improper rear suspension adjustment 3. Insufficient nitrogen gas pressure 	Replace Adjust Replace
Rear suspension is hard.	<ol style="list-style-type: none"> 1. Improper rear suspension adjustment 2. Spring thrust joint binding 3. Bent shock absorber rods 	Adjust Repair Replace
Braking effect is poor.	<ol style="list-style-type: none"> 1. Improper brake shoe contact 2. Brake linings fouled with oil or grease 3. Broken brake cable or loose brake pedal shaft 	Repair or replace Replace Repair or replace
Brake free play is insufficient.	<ol style="list-style-type: none"> 1. Worn brake shoes 2. Worn brake cam 3. Improper brake arm position 	Replace Replace Repair or replace

2. TORQUE SPECIFICATIONS

Item	Thread dia. x pitch	Torque	
		kg-m	lb-ft.
ENGINE			
Cylinder head	M 8 x 1.25	2.0 - 2.3	14.5 - 16.6
Cylinder	M10 x 1.25	3.8 - 4.8	27.5 - 34.7
A.C. generator rotor	M12 x 1.25	5.5 - 6.5	39.8 - 47.0
Clutch center	M18 x 1.0	4.0 - 5.0	28.9 - 36.2
Clutch spring	M 6 x 1.0	0.8 - 1.2	5.8 - 8.7
Clutch cover	M 6 x 1.0	0.7 - 1.0	5.9 - 7.2
Carburetor insulator	M 6 x 1.0	0.8 - 1.2	5.8 - 8.7
Drive gear	M10 x 1.25	4.0 - 5.0	28.9 - 36.2
FRAME			
Steering stem nut	M24 x 1.0	8.0 - 12.0	57.9 - 86.8
Fork top bridge	M 8 x 1.25	1.8 - 2.5	13.0 - 18.1
Handlebar upper holders	M 8 x 1.25	1.8 - 2.5	13.0 - 18.1
Fork bottom bridge pinch bolts	M 8 x 1.25	1.8 - 2.5	13.0 - 18.1
Front axle shaft	M12 x 1.25	5.5 - 7.0	39.8 - 50.6
Front axle nut	M12 x 1.25	5.5 - 7.0	39.8 - 50.6
Rear axle nut	M18 x 1.5	8.0 - 10.0	57.9 - 72.3
Engine mounting bolt	M10 x 1.25	3.8 - 4.8	27.5 - 34.7
Final driven sprocket	M 8 x 1.25	3.2 - 3.8	23.1 - 27.5
Rear brake torque link (front)	M10 x 1.25	3.8 - 4.8	27.5 - 34.7
(rear)	M10 x 1.25	3.0 - 4.0	21.7 - 28.9
Rear shock absorbers	M10 x 1.25	3.8 - 4.8	27.5 - 34.7
Step bar	M10 x 1.25	3.8 - 4.8	27.5 - 34.7
Gearshift pedal	M 6 x 1.0	1.0 - 1.4	7.2 - 10.1
Kickstarter arm	M 8 x 1.25	2.4 - 3.0	17.3 - 21.7
Seat	M 8 x 1.25	1.8 - 2.5	13.0 - 18.1
Steering top thread	M26 x 1.0	0.55 - 0.65	3.98 - 4.70
Front spokes	B.C 3.2	0.25 - 0.5	1.81 - 4.34
Rear spokes	B.C 3.5	0.25 - 0.5	1.81 - 4.34
Bead stopper	M 8 x 1.25	1.0 - 1.5	7.2 - 10.8
Front/rear spoke plates	M 6 x 1.0	1.4 - 1.6	10.1 - 11.6
Swing arm pivot bolt	M15 x 1.5	6.0 - 8.0	43.4 - 57.9

Standard Torques

Size	Torque kg-m (lb-ft.)	Size	Torque kg-m (lb-ft.)
6 mm screw	0.7 - 1.0 (5.1 - 7.2)	6 mm flanged nut	1.0 - 1.4 (7.2 - 10.1)
6 mm hex. bolt	0.8 - 1.2 (5.8 - 8.7)	8 mm flange bolt	2.4 - 2.9 (17.4 - 21.7)
8 mm hex. bolt	1.8 - 2.5 (13.0 - 18.1)	10 mm flange bolt	3.8 - 4.8 (27.5 - 34.7)
10 mm hex. bolt	3.0 - 4.0 (21.7 - 28.9)		

3. SERVICE DATA

ENGINE

mm (in.)

Item	Standard	Service Limit
Cylinder bore	69.980–69.995 (2.7551–2.7557)	70.05 (2.758)
Piston O.D.	69.93–69.95 (2.7531–2.7539)	69.800 (2.7480)
Piston pin hole	18.002–18.008 (0.7087–0.7089)	18.100 (0.7126)
Piston pin O.D.	17.992–18.000 (0.7083–0.7087)	17.980 (0.7079)
Piston ring end gap	Top	0.2–0.4 (0.008–0.016)
	Second	0.2–0.4 (0.008–0.016)
Piston ring-groove clearance	Second	0.025–0.050 (0.001–0.002)
Connecting rod small end I.D.	21.997–22.009 (0.8660–0.8665)	22.017 (0.8668)
Connecting rod big end side clearance	0.2–0.6 (0.008–0.024)	0.7 (0.028)
Connecting rod big end radial clearance	0.01–0.022 (0.0004–0.0009)	0.030 (0.0012)
Clutch disc thickness	2.62–2.78 (0.1031–0.1094)	2.4 (0.0945)
Clutch plate warpage	0.1 (0.004)	0.2 (0.008)
Clutch spring free length	32 (1.260)	30 (1.1811)
Clutch spring tension	18–20 kg/21 (39.7–44.1 lbs/0.827)	15 kg/21 (33.1 lbs/0.827)
Transmission gear backlash		0.2 (0.008)
Shift fork guide shaft O.D.	11.966–11.984 (0.4711–0.4718)	11.92 (0.4693)
Shift fork I.D.	12.000–12.018 (0.4724–0.4732)	12.05 (0.4744)
Shift fork pawl thickness	5.36–5.43 (0.2110–0.2138)	5.00 (0.1969)

FRAME

mm (in.)

Item	Standard	Service Limit
Drive chain length (108 link)	1,714.5 (67.5)	1,720.0 (67.7165)
Front fork spring free length	A	453 (17.835)
	B	529.5 (20.8465)
Rear shock absorber spring free length	354.8 (13.9685)	340 (13.3858)
Front fork tube O.D.	36.925–36.950 (1.4537–1.4547)	36.85 (1.4508)
Front fork bottom slider I.D.	37.065–37.104 (1.4593–1.4608)	37.25 (1.4665)
Wheel bearing axial play	0.07 (0.0028)	0.1 (0.004)
Wheel bearing radial play	0.03 (0.0012)	0.05 (0.002)
Front/rear axle runout	0.1 (0.004)	0.2 (0.008)
Front brake drum I.D.	140 (5.5118)	141 (5.5512)
Rear brake drum I.D.	160 (6.2992)	161 (6.3386)
Front brake lining thickness	4.5 (0.1772)	indicator (page 16)
Rear brake lining thickness	5 (0.1969)	indicator (page 17)
Front wheel rim runout	1.0 (0.04)	2.0 (0.08)
Rear wheel rim runout	1.0 (0.04)	2.0 (0.08)

4. ELECTRICAL WIRING DIAGRAM

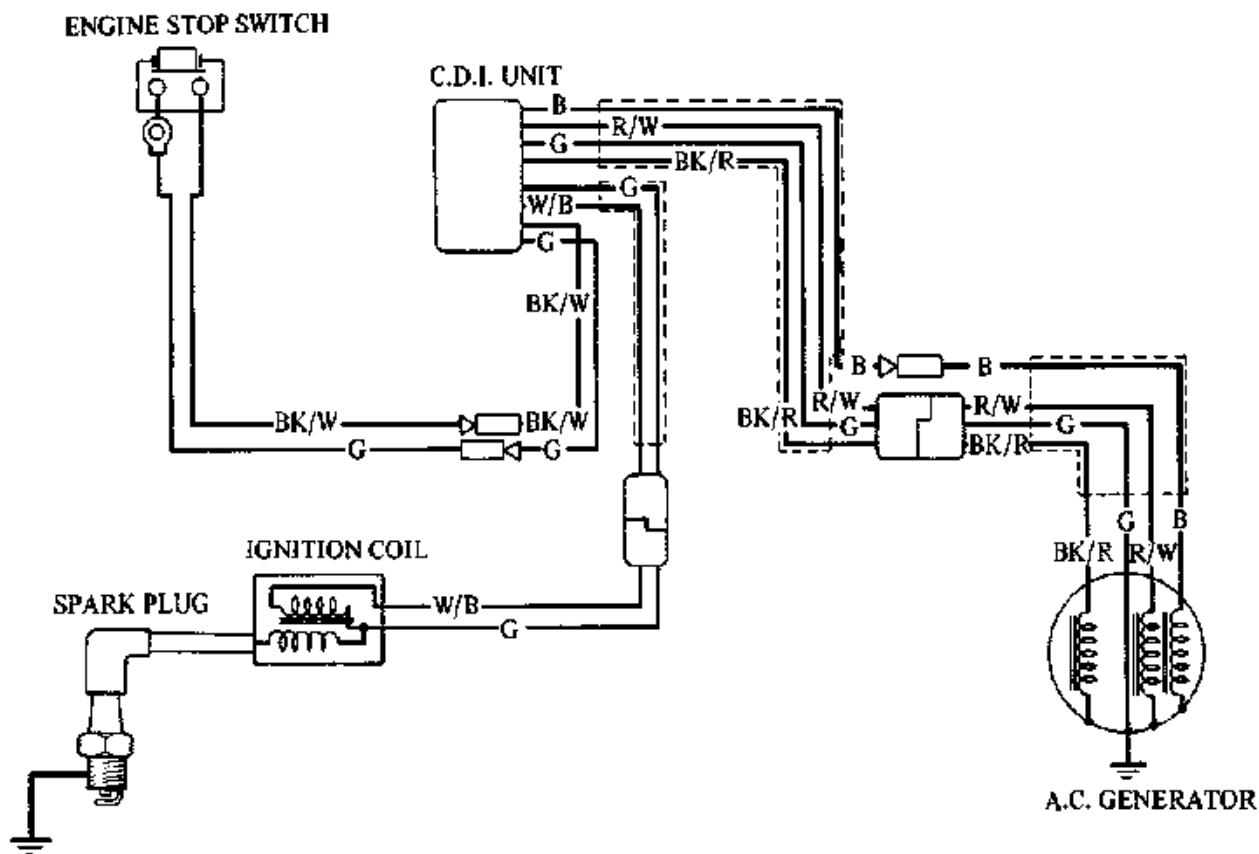

	IG	E
FREE		
PUSH		
CORD COLOR	Black/White	Green

- B Blue
- BK Black
- G Green
- R Red
- W White



Ref. No.	Tool No.	Description	Ref. No.	Tool No.	Description
(1)	07702-0010000	Pin spanner	(10)	07937-4300000	Case puller
(2)	07725-0010101	Universal holder	(11)	07953-4300000	Ball race remover
(3)	07916-4300000	Steering stem socket wrench	(12)	07746-0010100	Bearing driver attachment (front wheel)
(4)	07907-4150000	27 mm Lock nut wrench	(13)	07946-4300200	Bearing driver attachment (rear wheel/steering stem)
(5)	07917-3230000	6 mm Hollow set wrench	(14)	07946-3290000	Bearing driver attachment (rear wheel)
(6)	07910-4300000	Retainer wrench	(15)	07949-6110000	Driver handle
(7)	07933-4300000	Rotor puller	(16)	07947-3710000	Fork seal driver
(8)	07946-4300100	Bearing driver (steering stem)			
(9)	07924-4300000	Drive gear holder			

7. SPECIFICATIONS (for racing or competition)

	Item	Metric	English
Dimension	Overall length	2,145 mm	84.5 in.
	Overall width	890 mm	35.0 in.
	Overall height	1,190 mm	46.9 in.
	Wheel base	1,445 mm	56.9 in.
	Seat height	940 mm	37.0 in.
	Foot peg height	385 mm	15.2 in.
	Ground clearance	300 mm	11.8 in.
	Dry weight (without sub-muffler)	98 kg	216 lbs.
Frame	Type	Single cradle	
	F. suspension, travel	Telescopic fork, travel 300 mm (11.8 in.)	
	R. suspension, travel	Lay down swing arm, travel 280 mm (11.0 in.)	
	F. tire size, pressure	3.00-21 (4 PR), air pressure 1.2 kg/cm ² (17.0 psi)	
	R. tire size, pressure	5.10-18 (4 PR), air pressure 1.2 kg/cm ² (17.0 psi)	
	F. brake, lining area	Internal expanding shoes, lining swept areas 65 cm ² (10.1 sq. in.)	
	R. brake, lining area	Internal expanding shoes, lining swept areas 79.6 cm ² (12.3 sq. in.)	
	Fuel capacity	8.5 ℓ	2.2 U.S. gal. 1.9 Imp. gal.
	Caster angle	61° 15'	
	Trail length	118 mm	4.7 in.
	Front fork oil capacity	275 cc	9.3 ozs.
Engine	Type	Air cooled, 2-stroke engine	
	Cylinder arrangement	Single 7° inclined from vertical	
	Bore and stroke	70.0 x 64.4 mm	2.756 x 2.535 in.
	Displacement	247 cc	15.1 cu-in.
	Compression ratio	7.3 : 1	
	Transmission oil capacity	0.75ℓ	0.79 U.S. qt., 0.66 Imp. qt.
Carburetor	Type	Piston valve	
	Main jet (standard)	#185	
	Slow jet (standard)	# 60	
	Air screw opening	1-1/2	
	Float height	19 mm	0.75 in.
Drive train	Clutch	Wet, multi-plate type	
	Transmission	5-speed, constant mesh	
	Primary reduction	3.250	
	Gear ratio I	1.900	
	Gear ratio II	1.591	
	Gear ratio III	1.240	
	Gear ratio IV	1.000	
	Gear ratio V	0.839	

	Item	Metric	English
Drive train	Final reduction	3.500	
	Gear shift pattern	Left foot operated return system	
Electrical	Ignition	C.D.I. Ignition coil	
	Starting system	Kick starter	
	Spark plug	(CHAMPION) N-2G or (NGK) B9EV (for U.S.A. model) (CHAMPION) QN-2G, (NGK) BR9EV or (ND) W27ESR-G (for Canadian model)	



HONDA
HONDA MOTOR CO., LTD. TOKYO, JAPAN